



Touch Probe

Table of Contents

Overview	1
Parts Required	1
Installation	2
Set up touch probe	2
Go into ISO side of NCK	2
Verify machine data	2
Verify channel data	4
Reset the NCK	4
Load new measuring cycles	4
Probe Setup	9
Calibrate probe	9
Setup tools in Tool List	10
Measure tool	10
Appendix	11

TOUCH PROBE

Overview

A touch trigger probe, or touch probe, is used to set tool dimensions, such as length, radius, and insert lengths, automatically. When the touch probe is ordered as an option with a machine, it comes from the factory mounted on the left side of the table. This makes room for a rotary table installation. If desired, the touch probe can also be mounted on the right side of the table.

To use the touch probe, a measuring cycle subroutine is required. Measuring cycles are general subroutines designed to solve specific measurement tasks. Measuring cycle data must be adapted to the specific requirements of the individual machine, as well as, assign initial values.

Parts Required

<u>Qty</u>	<u>Part Number</u>	<u>Description</u>
1	ELE-0309	4.7kohm resistor
1	HDW-0035	T-slot nut, 1/2 - 13X5/8
1	PRB-0029	TS27R probe with holder
1	WIR-0051	Connector housing, 6 wire, female
1	WIR-0052	Connector housing, 6 wire, male
2	WIR-0056	Pin, 02-09-1204 brnz mlx, 22 awg
1	WIR-0099	Flex connector, 1/4 str s t
1	WIR-0123	Conduit, sealtite flex, 1/4, 76 inches (VMC3020), 81 inches (VMC4525)
1	WIR-0320	Conduit, black, high flex, 81 inches
1	WIR-0449	Connector, 1/4 inch flex
1	WIR-0451	Connector, black, swivel, 1/2 inch
1	WIR-0497	Connector, Furrell Appleton, 1/2 inch
2	WIR-0544	Pin, 02-09-2118 mlx, 22 awg

Installation

Set up touch probe

1. Mount the touch probe onto the front left corner of the table (See Figure 1).
2. Route signal cable from the probe to the CCU (compact control unit) electronics cabinet at the backside of the machine.
3. Following wiring diagram B in the Appendix, wire the female Molex connector (WIR-0051) with the signal wire coming from the touch probe. Install voltage drop resistor (ELE-0309) to pins one and two of the connector. Wire a 24 volt line from the power supply, mounted on the left side wall of the electronics cabinet, to the connector.
4. Plug the connector--that was just wired--to the prewired male Molex connector coming from interface connector X121 of the CCU module face panel (See Appendix wiring diagram A).

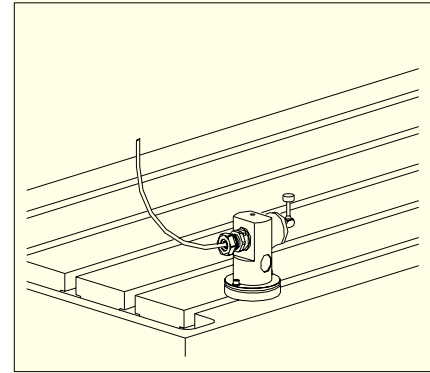







Figure 1 Mount touch probe at the front left corner of the table.

Go into ISO side of NCK

1. Go into the ISO side of the NCK (numerical control kernel). For MMC103, press the  System hard key. For MMC100, press **SHIFT + SYSTEM/ALARM** hard keys.
2. Press **CNC ISO > CNC ISO ✓** soft keys, then press the  Input hard key. Wait as the control switches over to the **ISO** side.
3. Press the **Startup** soft key.
4. Enter the password for manufacturer level access. For MMC103, press the  System hard key. For MMC100, press **SHIFT + SYSTEM/ALARM** hard keys.

NOTE: If the message bar--located at the bottom of the display screen--displays the message "Actual access level: Manufacturer," then the password is already set. Continue to "Verify machine data" below.
5. Press the **Set Password** soft key.
6. Enter password into the designated field. Type **SUNRISE**, in all uppercase lettering, in the password field.
7. Press the  Input hard key, then press the **OK** soft key.

Verify machine data

1. For MMC103, press the  System hard key. For MMC100, press **SHIFT + SYSTEM/ALARM** hard keys.
2. Press the **Startup** soft key.

3. Press the **Machine data** soft key.
4. Press the **Display data** soft key. On the MMC103, press the **Display MD** soft key.
5. Using the arrow hard keys to navigate, find each machine data line, listed in Table 1, on the display screen. Verify the machine data values found on the display matches the machine data values in Table 1.







9750 CMM_MEAS_PROBE_INPUT = 0	Measuring input for workpiece probe (This value must be 0 for a Fadal 810D/840D)
9751 CMM_MEAS_T_PROBE_INPUT = 0	Measuring input for tool probe (This value must be 0 for a Fadal 810D/840D)
9752 CMM_MEAS_DIST = 1.0 (inches, 50.8mm)	Maximum measuring distance--before and after the measuring point--for automatic measuring in the program
9753 CMM_MEAS_DIST_MAN = 2.0 (inches, 50.8mm)	Maximum measuring distance for manual measuring --before and after the measuring point
9754 CMM_MEAS_DIST_TOOL_LENGTH = .5 (inches, 50.8mm)	Maximum measuring distance for tool length--before and after the measuring point
9755 CMM_MEAS_DIST_TOOL_RADIUS = 1.0 (inches, 25.4mm)	Maximum measuring distance for tool radius--before and after the measuring point
9756 CMM_MEASURING_FEED = 10 (ipm, 1270mm)	Measuring feedrate
9757 CMM_FEED_WITH_COLL_CTRL = 25 (ipm, 635mm)	Plane feedrate with collision monitoring
9758 CMM_POS_FEED_WITH_COLL_CTRL = 25 (ipm, 635mm)	Infeed rate with collision monitoring
9759 CMM_MAX_CIRC_SPEED_ROT_SP = 15 (inches, 381mm)	Maximum circumferential speed during tool measuring with rotation spindle
9760 CMM_MAX_SPIND_SPEED_ROT_SP = 500 (rpm)	Maximum speed during tool measuring with rotating spindle
9761 CMM_MIN_FEED_ROT_SP = 10 (ipm, 254mm)	Minimum feedrate during tool measuring with rotating spindle
9762 CMM_MEAS_TOL_ROT_SP = .001 (ipm, .0254mm)	Measurement accuracy during tool measurement with rotating spindle
9763 CMM_TOOL_PROBE_TYPE = 0	Tool probe type (This must be 0 for a Fadal 810D/840D)
9764 CMM_TOOL_PROBE_ALLOW_AXIS = 133	Allowed axis directions for tool probe (ZXY) (This must be 133 for a Fadal 810D/840D)
9765 CMM_T_PROBE_DIAM_LENGTH_MEAS = .1 (inches, 2.54mm)	Tool probe diameter for length measurement
9766 CMM_T_PROBE_DIAM_RAD_MEAS = .5 (inches, 12.7mm)	Tool probe diameter for radius measurement
9767 CMM_T_PROBE_DIST_RAD_MEAS = .25 (inches, 6.35mm)	Infeed distance of tool probe upper edge for radius measurement
9768 CMM_T_PROBE_APPROACH_DIR = -1 (negative motion in the Z-axis)	Plane approach direction, tool to the tool probe

Table 1: Machine data lines and their descriptions.

Verify channel data

1. Press the **Channel data** soft key. On the MMC103, press the **Channel MD** soft key.
2. Using the arrow keys to navigate, locate the following channel machine data lines:
 - 28000 MM_REORG_LOG_FILE_MEM = 20
 - 28010 MM_NUM_REORG_LUD_MODULES = 8

Reset the NCK

1. For MMC103, press the  **System** hard key. For MMC100, press **SHIFT + SYSTEM/ALARM** hard keys.
2. Press the **Startup** soft key.
3. Press the **NCK reset** soft key. An overlay box labeled "Start-up" will display asking if an NCK power on reset is desired.
4. Press the **Yes** soft key to accept a the NCK reset. Wait as the NCK resets.
5. Reference each axis.
 - IF REQUIRED, manually jog each axis to its alignment marks.
 - a) Press the  **MPG** hard key. Wait for the LED above the key to illuminate.
 - b) Select an axis with the axis selector switch.
 - c) Align the selected axis to its mark by using the handwheel.
 - d) Repeat steps 2 and 3 for all the axes.
 - e) Press  **JOG** hard key when done.
 - Reference the axes.
 - f) Select an axis with the axis selector switch.
 - g) Press the  **REF POINT** hard key.
 - h) Press the  "plus" hard key.
 - i) Repeat steps 2, 3, and 4 for all the axes.
 - j) The axes are referenced when the crosshair symbol  displays to the left of each axis.

Load new measuring cycles

The new measuring cycles are contained in the utilities diskette supplied with the touch probe kit. These measuring cycles update the ones currently in the NCK. Determine which option, MMC103 or MMC100, the machine has and follow those steps to upload the new measuring cycles.

MMC103

1. Press the  **System** hard key.
2. Press the **Services** soft key.
3. Press the **Data in** soft key.
4. Press the **Disk...** soft key. Insert the utilities diskette in the floppy disk drive when prompted to do so, then press the **OK** soft key.
5. An overlay box appears displaying the contents of the utilities diskette. Using the arrow hard keys, select the file *Bt.tea*. The file is selected when it is highlight with the blue bar.
6. Press the **Start** soft key.
7. Press the **Yes all** soft key to accept the overwriting of the existing *BDO301_TEA* file. The message "Job is ready" displays at the bottom of the screen when the file is finished uploading.
8. Repeat steps 4, 5, 6, and 7 for the remaining measuring cycles listed below.

CYCLE107_SPF	CYCLE971_SPF	E_MS_PIN_SPF
CYCLE108_SPF	CYCLE976_SPF	E_MT_CAL_SPF
CYCLE109_SPF	CYCLE977_SPF	E_MT_LEN_SPF
CYCLE111_SPF	CYCLE978_SPF	E_MT_RAD_SPF
CYCLE114_SPF	E_MS_CAL_SPF	
CYCLE198_SPF	E_MS_CAN_SPF	
CYCLE199_SPF	E_MS_HOL_SPF	

9. Return to Shopmill.
10. Press the **Shopmill** soft key. Wait as the control switches over to Shopmill.
11. Press the **Machine manual** soft key.
12. Press the **Setting** soft key.
13. Verify and modify, if necessary, the setting data:

	<u>DATC Data</u>	<u>ATC Data</u>
Retract: Z	.750	1.0
Safety: Z	.100	0.1
Feed:	10 ipm	10 ipm
Jog Increment:	100	100

MMC100

Setup requires an external computer with a 3.5 inch floppy disk drive and the PCIN communications program loaded. The new measuring cycles are uploaded to the MMC100 from the utilities diskette using the external computer.

Set up communications parameters

1. Press the **Shift + SYSTEM /ALARM** hard keys.
2. Press the CNC ISO soft key, then the CNC ISO ✓ soft key.
3. Verify the user access level:
4. Press the **Shift + SYSTEM/ALARM** hard keys.
5. Press the **STARUP** soft key.
6. The message “**Actual access level: Manufacturer**” should display in the message bar at the bottom of the screen display. If the level is not set to Manufacturer or no message displays, continue at “d.” If the level is set to Manufacturer, go to step 4.
7. Press the **Set password** soft key.
8. Type **SUNRISE**. The password is set in all uppercase letters. If necessary, press the **Shift** hard key while typing the password.
9. Press the **Shift + SYSTEM/ALARM** hard keys.
10. Press the **Services** soft key.
11. Press the **Data out** soft key.
12. Highlight the *Start-up data* line using the up and down arrows.
13. Press the **RS232 C User** vertical soft key.
14. Press the **Set** soft key. At this point, two options columns are displayed (See Figure 2). The left options column is the parameters for communications. The right options column is the “Special Functions.”

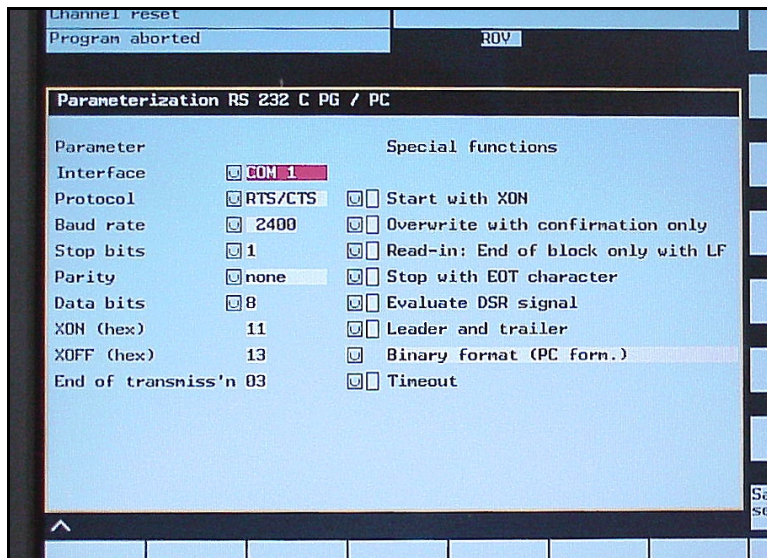

Figure 2 Communications parameter settings for MMC100.

The parameters for communications should be as follows:

Interface: **COM1**
Protocol: **RTS/CTS**
Baud Rate: **2400** (see note below)
Stop Bits: **1**
Parity: **none**
Data bits: **8**
Xon: **11**
Xoff: **13**
End of Trans: **03**

NOTE: On external computers loaded with either the Windows 95 or NT 4.0 operation system, a baud rate of 4800bps or higher may also be used. On external computers loaded with the Windows 98 operating system, setting a baud rate above 2400bps can cause a data transmission failure. In either case, if a transmission failure were to occur, use a baud rate of 2400bps.

“**Binary Format (PC form)**” should be selected on the second-to-last line in the *Special Functions* column. Also, all the boxes to the left of each line, in the *Special Functions* column, should be clear.

15. Press the **Save setting** vertical soft key.

Set up external computer

The communication parameters at the external computer must correspond to the communication parameters at the control. If applicable, set LPT1 to bi-directional in the BIOS of the external computer.

NOTE: The PCIN communications program is a DOS based program. Therefore, an RTS/CTS error may occur if PCIN is being run in Microsoft Windows. If an error occurs, try turning off power management in Windows, turning off the screen saver, and restarting the computer in DOS mode. If an error still occurs, consult your IT department for further assistance.

1. Start up the PCIN communications program.
2. Select **V24_INI** at the top of the screen (See “a” in Figure 3). Press **ENTER**, two times if necessary, to display the communication parameters box.
3. Set **COM** number to “1” or “2” (depending on the COM port communications cable connection at the external computer). Navigate to the **COM NUMBER** line using the arrow keys. Use the arrow keys to select the proper COM port settings (See “b” in Figure 3).

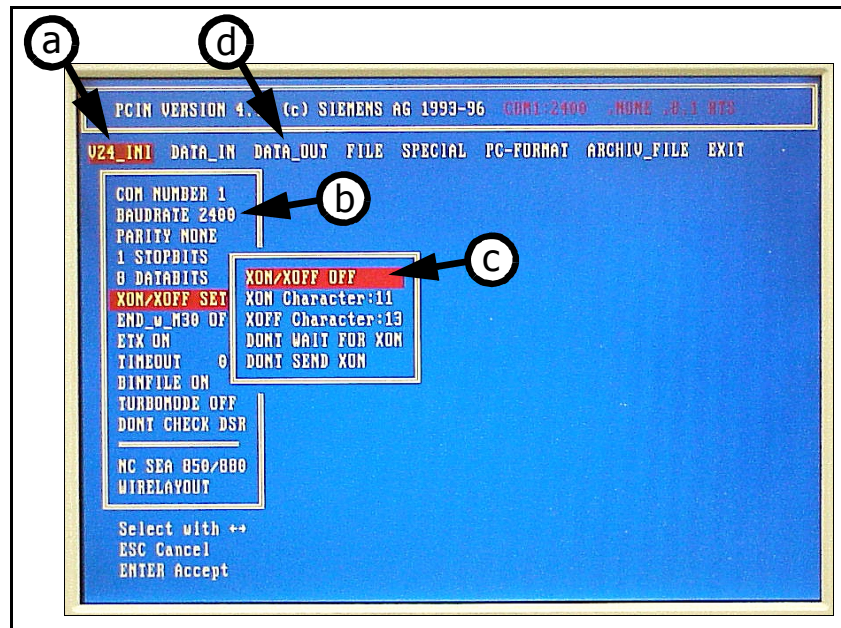

Figure 3 PCIN screen display with the communication parameters box opened.

4. Set XON/XOFF parameter to "OFF." Use the arrow keys to navigate to the *XON/XOFF SET* line. Use the arrow keys to select *ON* or *OFF* setting in the box that displays (See "c" in Figure 3).
5. Set ETX to "ON."
6. Press ENTER.
7. Select YES in the *SAVE INPUT (Y/N)* box that displays.
8. Select *DATA_OUT* at the top of the screen (See "d" in Figure 3).
9. Press ENTER.

Upload new measuring cycles

1. Insert the utilities diskette into the floppy drive of the external computer.
2. Type **a:** in the *Filename* box.
3. Press ENTER. The contents of the utilities diskette displays in the *a:* directory box.
4. Select the *Bt.tea* file.
5. Press the ENTER key.
6. At the pendant, press the **Start** soft key.
7. Press the OK soft key. The *Transmission in Progress!* window displays.
8. Press the OK soft key to upload the file. The *Transmission in progress!* window closes when the data transfer is complete.

9. Repeat steps 4, 5, 6, 7, and 8 for the remaining measuring cycles listed below.

CYCLE107_SPF	CYCLE971_SPF	E_MS_PIN_SPF
CYCLE108_SPF	CYCLE976_SPF	E_MT_CAL_SPF
CYCLE109_SPF	CYCLE977_SPF	E_MT_LEN_SPF
CYCLE111_SPF	CYCLE978_SPF	E_MT_RAD_SPF
CYCLE114_SPF	E_MS_CAL_SPF	
CYCLE198_SPF	E_MS_CAN_SPF	
CYCLE199_SPF	E_MS_HOL_SPF	

10. Return to Shopmill. Press the **SHIFT + SYSTEM/ALARM** hard keys.

11. Press the **Shopmill** soft key. Wait as the control switches over to Shopmill.

12. Press the **Machine manual** soft key.

13. Press the **Setting** soft key.

14. Verify and modify, if necessary, the setting data:

	<u>DATC Data</u>	<u>ATC Data</u>
Retract: Z	.750	1.0
Safety: Z	.100	0.1
Feed:	10 ipm	10 ipm
Jog Increment:	100	100

Probe Setup

Calibrate probe

NOTE: The calibrated probe data will stored and set for the tool probe parameters.

1. Select a tool, such as an end mill tool, to use as the calibration tool for the probe. Load the tool into the spindle.
2. Jog the calibration tool over to the touch probe. Position the tool approximately two inches (2") above the center of the measuring surface of the touch probe.
3. For MMC103, press the **System** hard key. For MMC100, press **SHIFT + SYSTEM/ALARM** hard keys.
4. Press the **Machine manual** soft key.
5. Press the **Measure tool** soft key.
6. Press the **Calibrate probe** soft key.
7. Press the **Alternate** soft key to select the Length and diameter measurement option.

8. Press the  **CYCLE START** (green) hard key. Calibration is executed automatically at the measuring feedrate. The current distance measurements between the machine zero and touch probe are calculated and stored in an internal data area.

Setup tools in Tool List

1. For MMC103, press the **System** hard key. For MMC100, press **SHIFT + SYSTEM/ALARM** hard keys.
2. Press the **Tool zero offset** soft key.
3. Modify the tools in the tool list so they correspond to the tools in the turret.
NOTE: Endmills require a diameter and "endmill" selected as the description. Drills require an angle and "drill" selected as the description.

Measure tool

1. For MMC103, press the **System** hard key. For MMC100, press **SHIFT + SYSTEM/ALARM** hard keys.
2. Press the **Machine Manual** soft key.
3. Press the **Measure tool** soft key.
4. Position the tool close to the measuring surface of the touch probe.
5. Press the **Length auto** soft key.
6. Press the  **CYCLE START** hard key. The measurement is taken automatically at the measuring feedrate. The tool dimension data is calculated and stored in the tool list.
7. Load the next tool from the turret.
8. Repeat this step for all the tools being measured.

Appendix

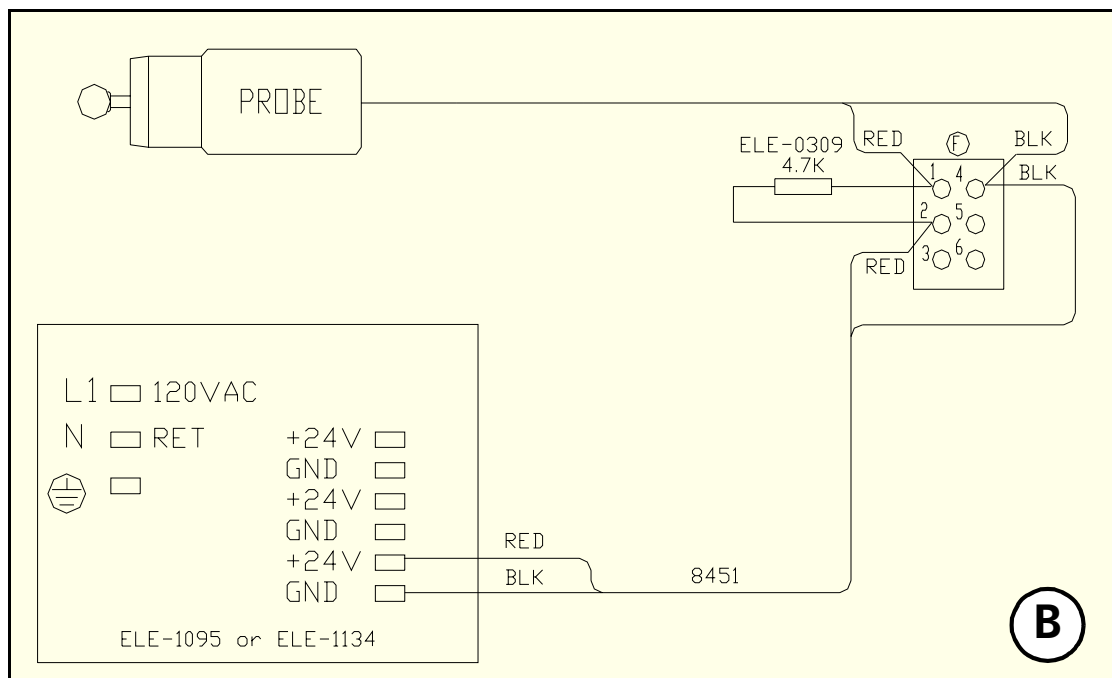
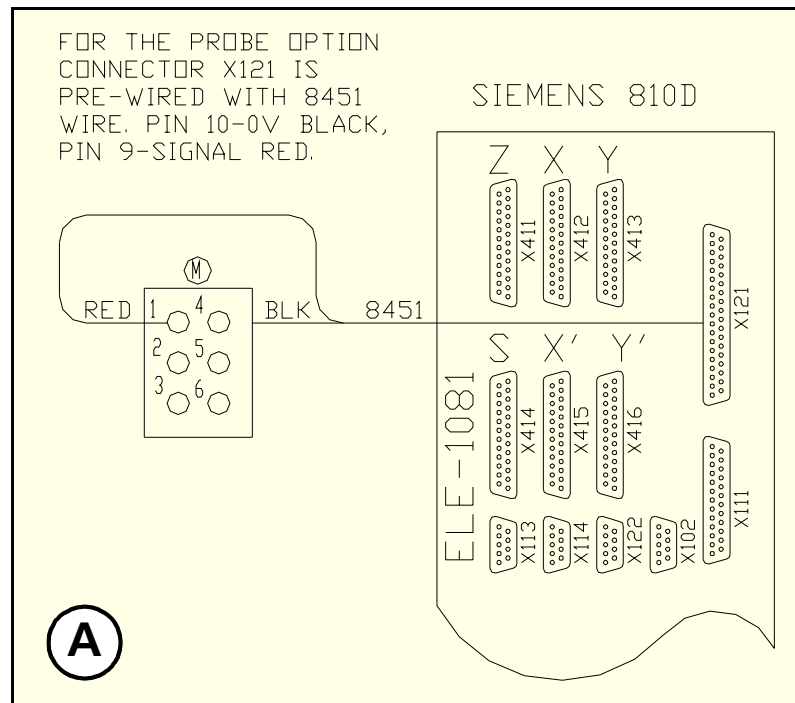

Wiring Diagram - TS27 Probe

This page intentionally left blank.