Section 02: Pre-Installation Procedures

Foundation



WARNING

The VMC *MUST* be placed on a surface that will support the combined weight of the VMC, options, fixtures, and tooling, etc. (refer to the VMC Specifications section at the beginning of this manual for VMC weights).

- 1) It is recommended that all models be placed on a isolated concrete pad 8-12 inches thick (Figure 2-1, Dimension C). For A and B dimensions, see Table 1.

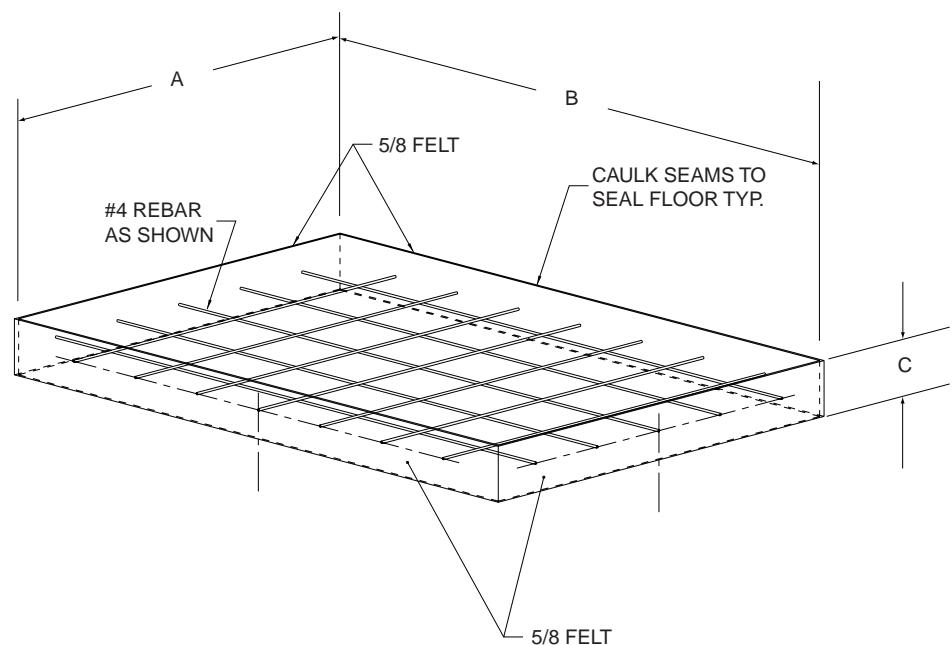
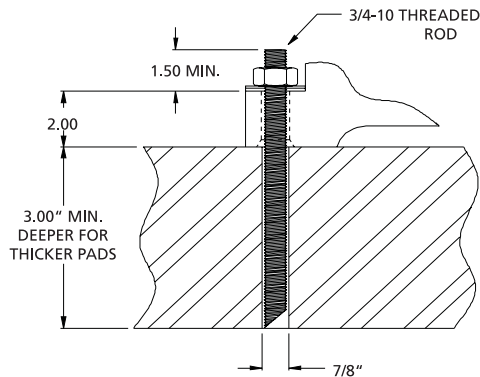

Figure 2-1 Typical Pad Construction

- 2) The VMC should be positioned on a single slab. Placing the VMC over an expansion joint may cause the VMC to shift when each individual slab moves.
- 3) The surface below the leveling pads should be free from cracks. Placing the VMC over a crack may cause the VMC to shift during use. *Inadequate flooring could result in mechanical degradation.*

- 4) Bolt the VMC directly to the pad through the .953" diameter holes that are provided in the base casting. The dimensions for the base mounting holes of all machines are in the VMC Specifications section. Anchors are to be installed as shown below in Figure 2-2. For high performance machines, the machine must be bolted to achieve maximum performance.



RECOMMENDED CURING TIME

58°F TO 68°F	30 MIN
50°F TO 58°F	1 HR
41°F TO 50°F	2 HRS
32°F TO 41°F	4 HRS
23°F TO 32°F	8 HRS
14°F TO 23°F	24 HRS

ANCHOR STUD INSTALLATION:

1. WEAR SAFETY GOGGLES.
2. USE 7/8 CARBIDE TIPPED DRILL FOR THE ANCHOR YOU ARE USING.
3. USE A ROTARY-HAMMER DRILL AND DRILL THE BASE MATERIAL TO DEPTH.
4. **CAUTION! USE PROPER EYE AND HEARING PROTECTION WHILE PERFORMING THIS STEP.** REMOVE DUST AND RUBBLE FROM THE HOLE WITH COMPRESSED AIR, AND BRUSH.
5. INSERT CAPSULE IN THE HOLE, EITHER END FIRST.
6. SELECT PROPER 1/2" SQ. DRIVE SOCKET AND ATTACH TO SUP-R-SETTER.
7. JAM NUT ON STUD AS PER ILLUSTRATION.
8. USING A 1 1/8" SOCKET INSERT THE STUD INTO THE HOLE TO BREAK THE CAPSULE.
9. UNDER ROTARY POWER, PUSH THE STUD TO FULL DEPTH, MAINTAINING POWER FOR TWO OR THREE SECONDS AFTER THE STUD BOTTOMS.
10. PROMPTLY AND CAREFULLY RELEASE THE INSTALLATION TOOL FROM THE STUD, LEAVING IT UNDISTURBED RIGHT THROUGH THE PRESCRIBED CURING TIME CONSISTENT WITH ON-SITE TEMPERATURE.
11. INSTALL MACHINE.
12. LEVEL MACHINE.
13. ADD TWO FLAT WASHERS, ONE LOCK WASHER AND ONE NUT PER THREADED ROD.
14. TIGHTEN NUT, STOP WHEN WASHER GETS FLAT, DO NOT OVERTIGHTEN.
15. RECHECK LEVEL.

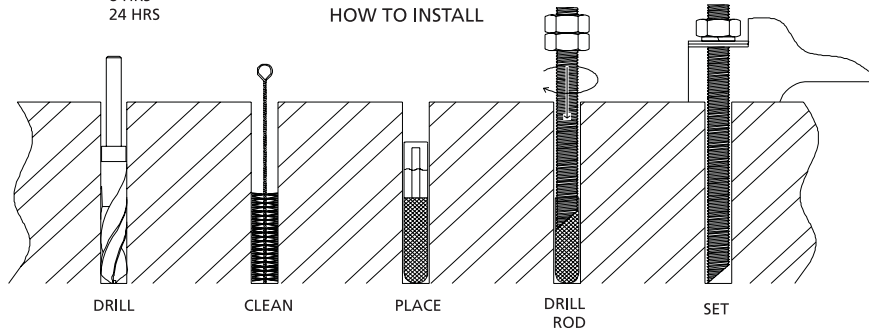

Figure 2-2 Anchor Stud Installation

Table 1: Isolation Pad Dimensions

Machine	A (depth)	B (width)
EMC/ 15/ 15XT/ 2016L	7 ft. 9 in.	7 ft. 7 in.
2216/ 3016	7ft 9in	9ft 6in
3016L	7ft 9in	9ft 10in
4020/ 4020A/ 5020A	8ft 7in	11ft
3020	8ft 5in	10ft 2in
4525	8ft 10in	12ft
6030	9ft 11in	14ft 6in
6535	9ft 11in	15ft 10in
8030	9ft 11in	18ft 9in
TRM	Not Required	Not Required

Shipping Dimensions

Table 2: VMC Shipping Dimensions

VMC	LENGTH	WIDTH	HEIGHT	WEIGHT	Z MTR DWN
8030	17ft 8in	8ft 8in	10ft 2in	19,000lbs	8ft 8in
6535	14ft 9in	8ft 10in	11ft 3in	30,000lbs	11ft 3in
6030	13ft 2in	8ft 8in	10ft 2in	17,000lbs	8ft 8in
5020A	9ft 7in	7ft	8ft 3in	10,500lbs	6ft 8in
5020A	9ft 7in	7ft	9ft 1in ext column	10,500lbs	7ft 5in
4525	8ft 10in	7ft 10in	10ft	13,600lbs	8ft 5in
4020A	9ft 7in	7ft	8ft 3in	10,500lbs	6ft 8in
4020A	9ft 7in	7ft	9ft 1in ext column	10,500lbs	7ft 5in
4020	9ft 7in	7ft	8ft 3in	10,500lbs	6ft 8in
4020	9ft 7in	7ft	9ft 1in ext column	10,500lbs	7ft 5in
3020	8ft 10in	6ft 10in	10ft	12,400lbs	8ft 5in
3016	8ft 3in	6ft 5in	8ft 2in	9,500lbs	6ft 8in
3016	8ft 3in	6ft 5in	8ft 8in ext column	9,500lbs	7ft 4in
2216	8ft 3in	6ft 5in	8ft 2in	9,100lbs	6ft 8in
2216	8ft 3in	6ft 5in	8ft 8in ext column	9,100lbs	7ft 4in
3016L	7ft 5in	6ft 5in	7ft 7in	6,100lbs	6ft 6in
3016L	7ft 5in	6ft 5in	8ft 4in ext column	6,100lbs	7ft 3in
2016L	6ft 2in	6ft 5in	7ft 7in	5,800lbs	6ft 6in
2016L	6ft 2in	6ft 5in	8ft 4in ext column	5,800lbs	7ft 3in
15XT	7ft 5in	6ft 5in	7ft 7in	5,800lbs	6ft 6in
15XT	7ft 5in	6ft 5in	8ft 8in ext column	5,800lbs	7ft 3in
15	6ft 2in	6ft 5in	7ft 7in	5,500lbs	6ft 6in
15	6ft 2in	6ft 5in	8ft 4in ext column	5,500lbs	7ft 3in
EMC	6ft 2in	6ft 5in	7ft 7in	5,500lbs	6ft 6in
TRM					
HYDRO	8ft 5in	4ft 2in	5ft 3in	820lbs	
PALLET	7ft 2in	3ft 3in	3ft 8in	911lbs	

Table 3: VMC Crated Dimensions and Weights

VMC	LENGTH	WIDTH	HEIGHT	WEIGHT
8030	17ft 8in	8ft 8in	10ft 2in	20,500lbs est
6535	17ft	8ft 10in	12ft 3in	32,000lbs est
6030	14ft	8ft 8in	10ft 2in	18,500lbs est
5020A	10ft 5in	8ft	8ft 7in	11,800lbs est
4525	10ft 5in	8ft	8ft 7in	12,000lbs est
4020A	10ft 5in	8ft	8ft 7in	11,800lbs est
4020	10ft 5in	8ft	8ft 7in	11,800lbs est
3020	9ft	8ft	8ft 7in	11,000lbs est
3016	9ft	7ft	8ft 7in	10,300lbs est
2216	9ft	7ft	8ft 7in	10,300lbs est
3016L	7ft 5in	6ft 5in	7ft 7in	7,000lbs est
2016L	6ft 2in	6ft 5in	7ft 7in	6,800lbs est
15XT	7ft 5in	6ft 5in	7ft 7in	6,300lbs est
15	6ft 2in	6ft 5in	7ft 7in	6,000lbs est
EMC	6ft 2in	6ft 5in	7ft 7in	6,000lbs est
HYDRO	9ft 3in	4ft 9in	6ft	1,420lbs est
PALLET	7ft 9in	4ft 9in	6ft	1,411lbs est

Note: VMC-TRM/15/15XT/2016L/3016L/6535 and 8030 do not get crated. They are placed on pallets and vacuum sealed.

Positioning

- 1) Place the VMC so that skylights or air vents are NOT directly overhead. Do not expose the machine to direct sunlight, or any other heat source. Do not place the machine in an area that will expose the machine to moisture, standing water, liquid or rain.

- 2) Ensure there is adequate room behind the VMC to fully open the rear cabinet door. Minimum clearance behind the machine is two feet (24"/ 60.96 cm.) (See Figure 2-3).

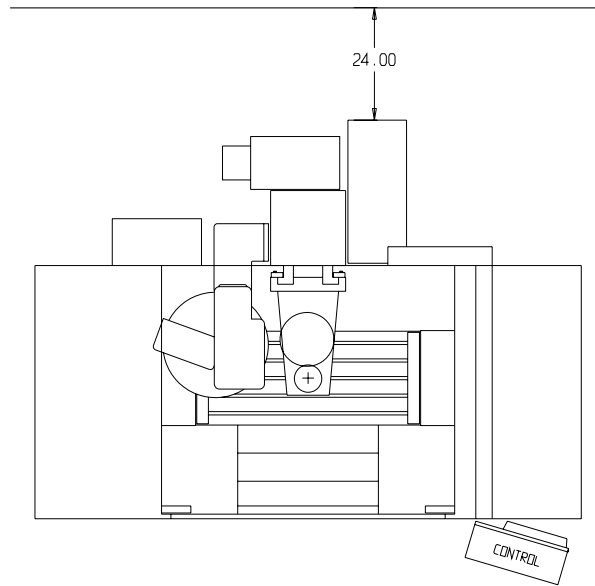

Figure 2-3 24" Minimum Clearance Behind VMC

- 3) Ensure adequate ceiling clearance for the Z axis conduit with the Z axis in the Z+4.0" position. VMCs with the Extended Travel option require an additional 8.0" vertical clearance. (See Table 4).

Table 4: Minimum Ceiling Clearances (inches)

	VMC EMC, 15, 15XT, TRM	VMC 2216, 3016	VMC 2016L, 3016L	VMC 4020, 4020A, 5020A	VMC 6030, 8030	VMC 3020, 4525	VMC 6535
Regular Column (Z+4.0")	95.00	97.00	97.00	98.00	126.00	127.00	140.00
Extended Column 28.0"	103.00	105.00	105.00	106.00	N/A	135.00	N/A

Air Supply



IMPORTANT

Air pressure required: 120psi before regulator, 80 psi after regulator, 15 scfm (standard cubic feet per minute) momentary.

- 1) From the main air supply line attach a 3/8" air supply line for the VMC. The distance from the air compressor and number of machines attached should be taken into consideration when determining the size of piping for the main air supply line.
- 2) Piping may consist of one or more of the following: galvanized pipe, PVC pipe or high pressure hose. Do not use quick disconnects; quick disconnects will restrict air flow.
- 3) A "T" riser should be used to connect the main air supply line with the air supply line to the VMC (see figure 4).
- 4) To prevent moisture from entering the VMC's air system, attach a drain to the lowest point of the air supply line. (See figure 2-4). The drain could be a self-relieving moisture separator, a simple petcock, or a gate valve opened occasionally to release the water build-up. An air dryer is preferred where higher moisture levels exist.
- 5) To help prevent contaminants from entering the air system on the VMC, place a filter in-line on the main air supply line.

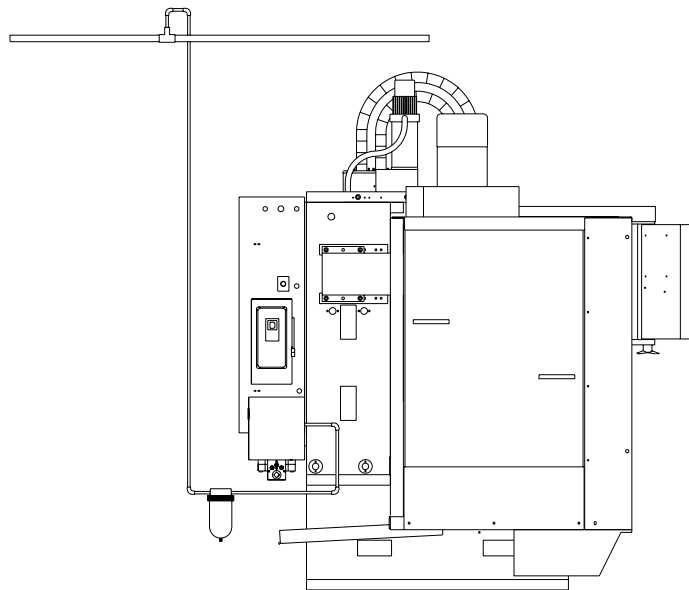

Figure 2-4 Attach Drain to Lowest Point of Air Supply Line

Electrical Grounding



IMPORTANT

The importance of proper grounding CANNOT be over-emphasized! Improper grounding will result in a wide range of hard-to-diagnose problems in communications, positioning, spindle motion, etc.

Primary Grounding (refer to NEC 1990 ARTICLE 250 SECTION 81)

- 1) The grounding conductor shall be of copper. The material selected shall be resistant to any corrosive condition existing at the installation or shall be suitably protected against corrosion.
- 2) The grounding conductor shall be a No. 8 AWG (10 mm²) or larger equipment ground conductor, and must be:
 - solid or stranded
 - insulated, covered, or bare
 - installed in one continuous length without a splice or joint.
- 3) Individually covered or insulated grounding conductors shall have a continuous outer finish that is either green, or green with one or more yellow stripes.
- 4) A No. 8 AWG (10 mm²) or larger equipment ground conductor and 3 phase conductors must be contained within one of the following:
 - rigid metal conduit
 - intermediate metal conduit
 - electrical metallic tubing
- 5) The ground conductor shall be connected between the VMC's ground bus and the approved ground bus contained within the voltage supply panel board or enclosure.
- 6) The VMC branch supply conduit, phase conductors and ground conductors must be dedicated to a single VMC. They cannot be used to supply any other loads.

Supplemental Grounding

(refer to NEC 1990 ARTICLE 250 SECTION 91)

- 1) Supplementary grounding electrodes shall be permitted to augment the equipment grounding conductor; however, the earth shall not be used as the sole equipment grounding conductor.
- 2) The supplemental grounding conductor shall be a No. 6 (16 mm²) or larger copper conductor in the form of a wire, and must be:
 - solid or stranded
 - insulated, covered or bare
 - installed in one continuous length without splice or joint

- 3) A No. 6 (16 mm²) or larger grounding conductor shall be run in one of the following:
 - rigid metal conduit
 - intermediate metal conduit
 - electrical metallic tubing or cable armor
- 4) One end of the supplemental grounding conductor shall be attached to the VMC's ground bus. The other end shall be effectively bonded to a copper cold water pipe that is in direct contact with the earth for 10 feet or more (see figure 2-5).
- 5) Connections shall be made so that they are electrically continuous.

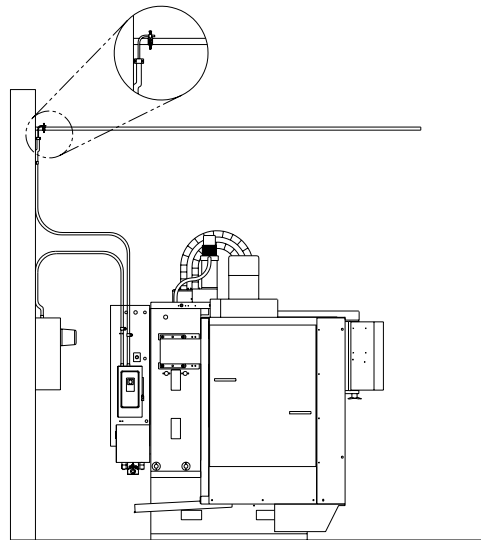

Figure 2-5 Bond Grounding Conductor to Copper Cold Water Pipe

Many problems that are difficult to diagnose can occur if the VMC is not properly grounded. Proper grounding cannot be overemphasized.

Checking Grounding Integrity of Fadal VMCs

Specification - Grounding for the Fadal machine:

- 1) MUST conform to NEC code as stated in the Maintenance Manual.
- 2) MUST be a continuous wire 8 AWG or larger between the VMC's ground bus and the building power distribution panel serving the VMC.

- 3) MUST be dedicated to a single VMC. (The ground and phase conductors cannot be shared with any other equipment.)
- 4) Ground rods and other supplemental grounding may be used in addition to the ground specified above but not instead of it.

**Inspection - Check
ground wire coming
into VMC:**

- 1) The ground wire coming into the VMC and going to the building power distribution panel must be 8AWG or larger.
- 2) The ground wire must be connected to the ground bar in the back cabinet of the VMC. (It does not go to a screw in the disconnect box.)
- 3) The ground wire is to be a continuous wire from the VMC to the building power distribution panel serving the VMC. The conduit is not to be used as the grounding conductor. Ground rods and other supplemental grounding may be used in addition to the ground specified above but not instead of it. Servicemen are not the appropriate people to be inspecting power distribution panels or building wiring. The serviceman is not expected to physically verify the routing of the ground conductor, but should look for any indications that grounding is not as specified.

**Verification - Check
grounding integrity
with Fluke meter:**

- 1) Measure the resistance (ohms) of a length of 16AWG or larger wire that is long enough to reach from the VMC to the building power distribution panel that supplies the VMC. Record reading.
- 2) Attach the wire of step 1 (test wire) to the ground bus of VMC. The other end will be used for measurement at the power distribution enclosure. (Do not open the enclosure. Use a bare screw or bare metal on the enclosure for measurements.)
- 3) Set meter to AC Volts; with VMC on, measure and record voltage between the test wire and the power distribution enclosure. Set meter to DC Volts; measure and record voltage. Voltages should be 0V with machine on but not operating, but up to .010V is OK.
- 4) Turn off the VMC and measure the ground voltages (AC and DC) again. Record these readings. Voltages should be 0V to .005V.
- 5) Voltages (AC or DC) across the ground wire will cause false resistance readings. If the ground voltages with VMC off are 0 (.005VAC max.), set meter to ohms and measure resistance between VMC ground bus and power distribution enclosure. Resistance measurement should be less than twice the resistance measured in step 1. (If resistance is negative (due to a ground current), reverse meter leads and average the two readings.)

Electrical Service

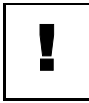

IMPORTANT

Electrical installation of machine must be done by a qualified electrician.

- 1) The total connected load should not exceed 75% of the panel rating, allowing for the VMC load. Refer to the Electrical Rating Plaque for full load current.
- 2) If other CNC equipment, motor controllers, motors or electric-discharge lighting (fluorescent, mercury vapor, metal-halide, high and low pressure sodium) are connected to the same panel, the connected load should not exceed 50% of the panels rated capacity.
- 3) Prior to the installation of the VMC, the panel should be measured for average and peak loads across the three phases.

WARNING



The VMC must NOT be installed on a panel where the measured surge demand current exceeds the panel's supply amplitude.

Preferred Service

The VMC should be supplied by a dedicated circuit connected directly to the Service Entrance panel.

Alternate Service

The VMC may be supplied by a dedicated circuit connected directly to the local branch panel.

Circuit Breakers

See Table 17 Section 1

Wiring

(refer to NEC 2002 ARTICLE 310 TABLE 310-16)

Table 5: Wiring Requirements

40 Taper	240 VAC 3 Ø	8 AWG (10 mm ²) stranded THHN copper within 100 ft. of panel. For VHT 4AWG	6 AWG (16 mm ²) stranded THHN copper 100 ft. or more from panel. For VHT 3 AWG
40 Taper	480 VAC 3 Ø	10 AWG (6 mm ²) stranded THHN copper within 100 ft. of panel. For VHT 6 AWG	8 AWG (10 mm ²) stranded THHN copper 100 ft. or more from panel. For VHT 4 AWG
40 Taper	240 VAC Single Ø	6 AWG (16 mm ²) stranded THHN copper within 50 ft. of panel.	4 AWG (25 mm ²) stranded THHN copper from 50 to 100 ft. from panel.
50 Taper	480 VAC 3 Ø	8 AWG (10 mm ²) stranded THHN copper within 100 ft. of panel. For VHT 4AWG	6 AWG (16 mm ²) stranded THHN copper 100 ft. or more from panel. For VHT 3 AWG

Conduit

(refer to NEC 2002 ARTICLE 300-17 and Annex C TABLE C1)

- 1) The number and size of conductors in any raceway shall not be more than will permit dissipation of the heat.
- 2) The conduit must allow ready installation or withdrawal of the conductors without damage to the conductors or to their insulation.

Table 6: Conduit Selection

# of Conductors	Conductor Size	Minimum Size of Conduit
4	10 AWG THHN (6 mm ²)	1/2"
4	8 AWG THHN (10 mm ²)	3/4"
4	6 AWG THHN (16 mm ²)	3/4"
3	4 AWG THHN (25 mm ²)	1.0"

This page intentionally left blank.