

SECTION 11

Washdown

WRG_0037F_auger_washdown_coolantthru

1310 PIN LIST

- J1**

 - 120 VAC (INPUT)
 - PUMP
 - VALVE #1
 - VALVE #2
 - VALVE #3
 - 120 RETURN (INPUT)
 - E-STOP (INPUT)
 - CONTACTOR FOR AUGER
 - CONTACTOR FOR SPINDLE
 - RETURN FOR SPINDLE CONTACTOR
 - RETURN FOR AUGER CONTACTOR AND PUMP STARTER
 - RETURN FOR VALVE COILS

- J2**

 - 1-3. AUGER MOTOR
 - 4-7. 220 VAC

- J3**

 - START/STOP BUTTON
 - MODE SWITCH
 - M-FUNCTION INPUT
 - POT
 - +5V FOR PDT
 - GROUND
 - EXTERNAL RESET
 - +5V
 - +5V (INPUT)
 - GROUND (INPUT)
 - EXTERNAL SLIDE HOLD OUTPUT
 - GROUND FOR EXTERNAL SLIDE HOLD

- J4**

 - LEFT DOOR SWITCH (BLK)
 - LEFT DOOR SWITCH (WHT)
 - LEFT DOOR SWITCH (RED)
 - LEFT DOOR SWITCH (GRN)
 - RIGHT DOOR SWITCH (BLK)
 - RIGHT DOOR SWITCH (WHT)
 - RIGHT DOOR SWITCH (RED)
 - RIGHT DOOR SWITCH (GRN)
 - FRONT DOOR SWITCH (BLK)
 - FRONT DOOR SWITCH (WHT)
 - FRONT DOOR SWITCH (RED)
 - FRONT DOOR SWITCH (GRN)

- K1 - SSR ELE-0070 TURN ON PUMP.
- K2 - SSR ELE-0070 VALVE 1.
- K3 - SSR ELE-0070 VALVE 2.
- K4 - SSR ELE-0070 VALVE 3.
- K6 - SSR ELE-0070 3 POLE RELAY 240V.
- K101 - SSR ELE-0101 SPINDLE RELAY

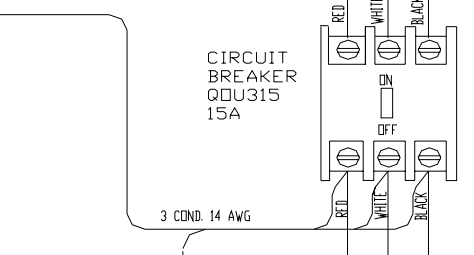
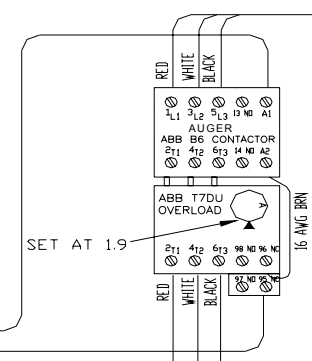
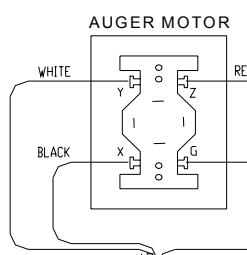
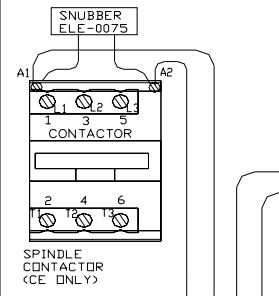

T-820 TRANSFORMER

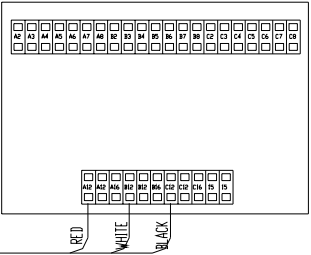

NOTE: IF MACHINE HAS ALSO HAS PALLET CHANGER AND DUAL ARM TDOL CHANGER THEN A SECOND 15 A CIRCUIT BREAKER WILL BE REQUIRED. UL LIMIT FOR BRANCH MOTOR PROTECTION IS 15 A.

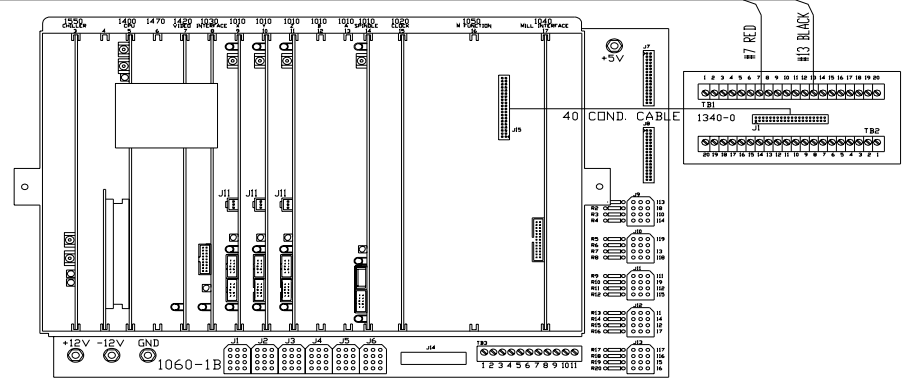
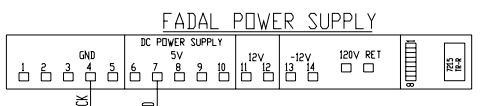
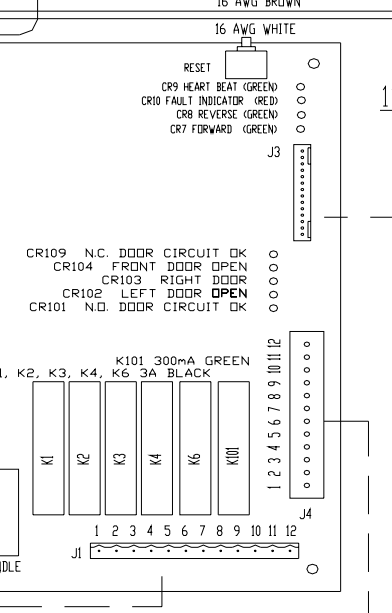
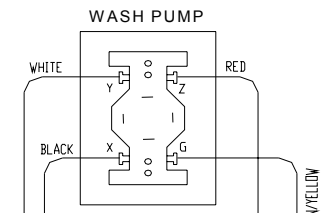
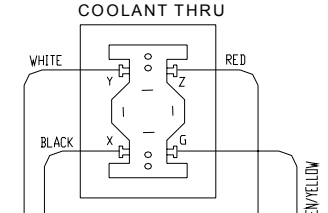
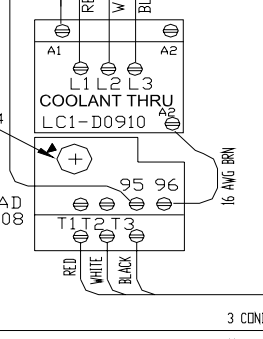
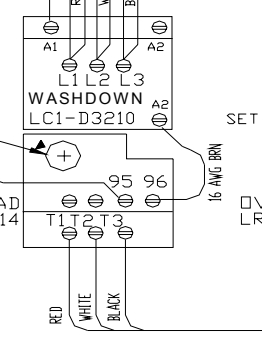
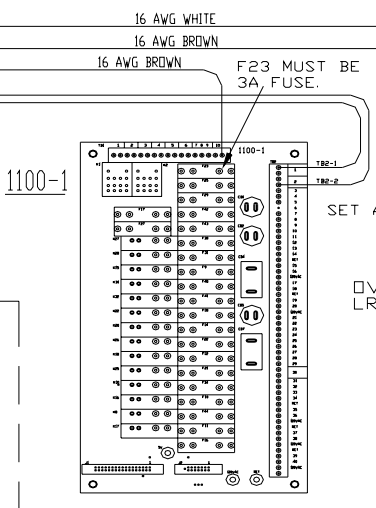

NOTE: REMOVE DOOR INTERLOCK FROM J13 PIN 8 & INSTALL AUGER INTERLOCK

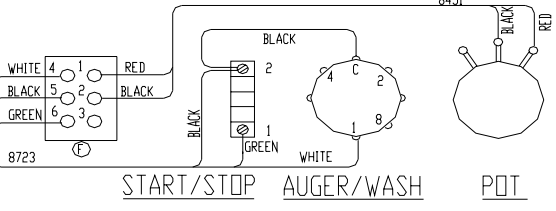
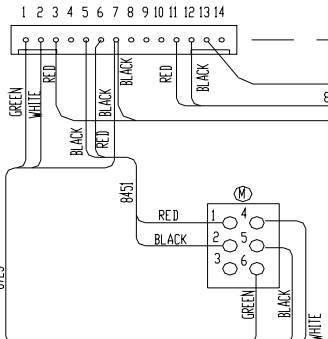
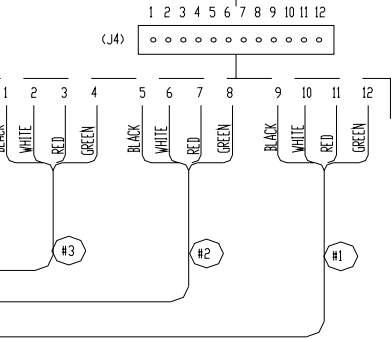
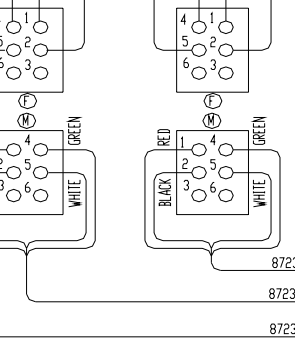
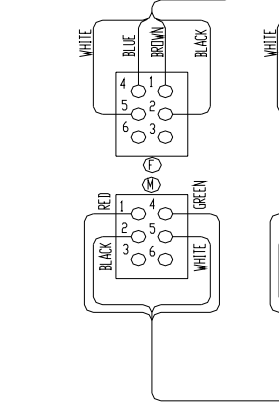
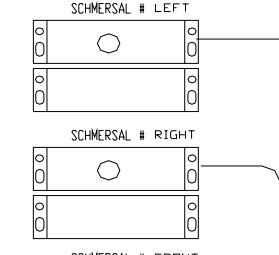

WRG_0044D_6535_washdown

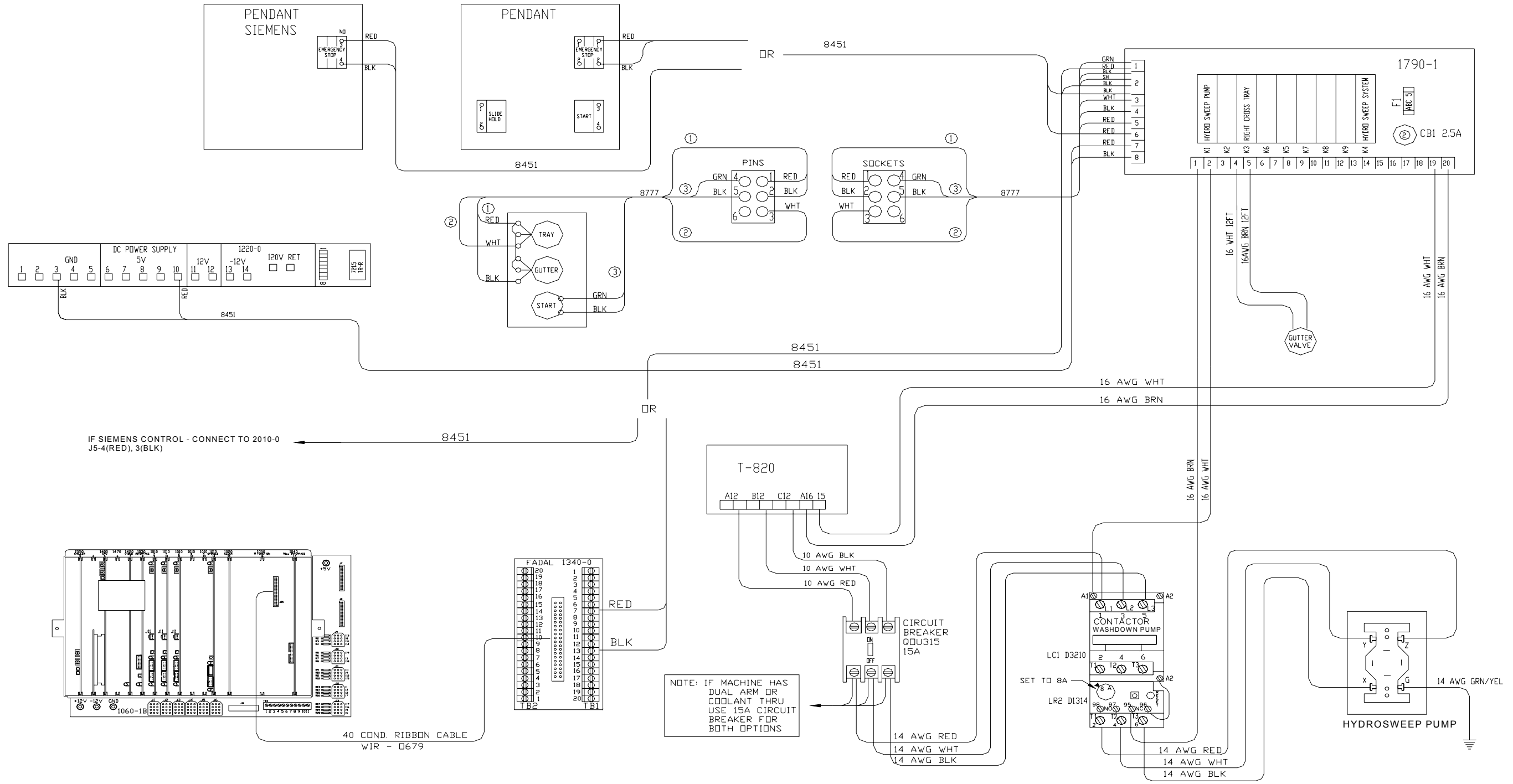

Wrg_0081X_15of22_hmc_wash_conv_cool

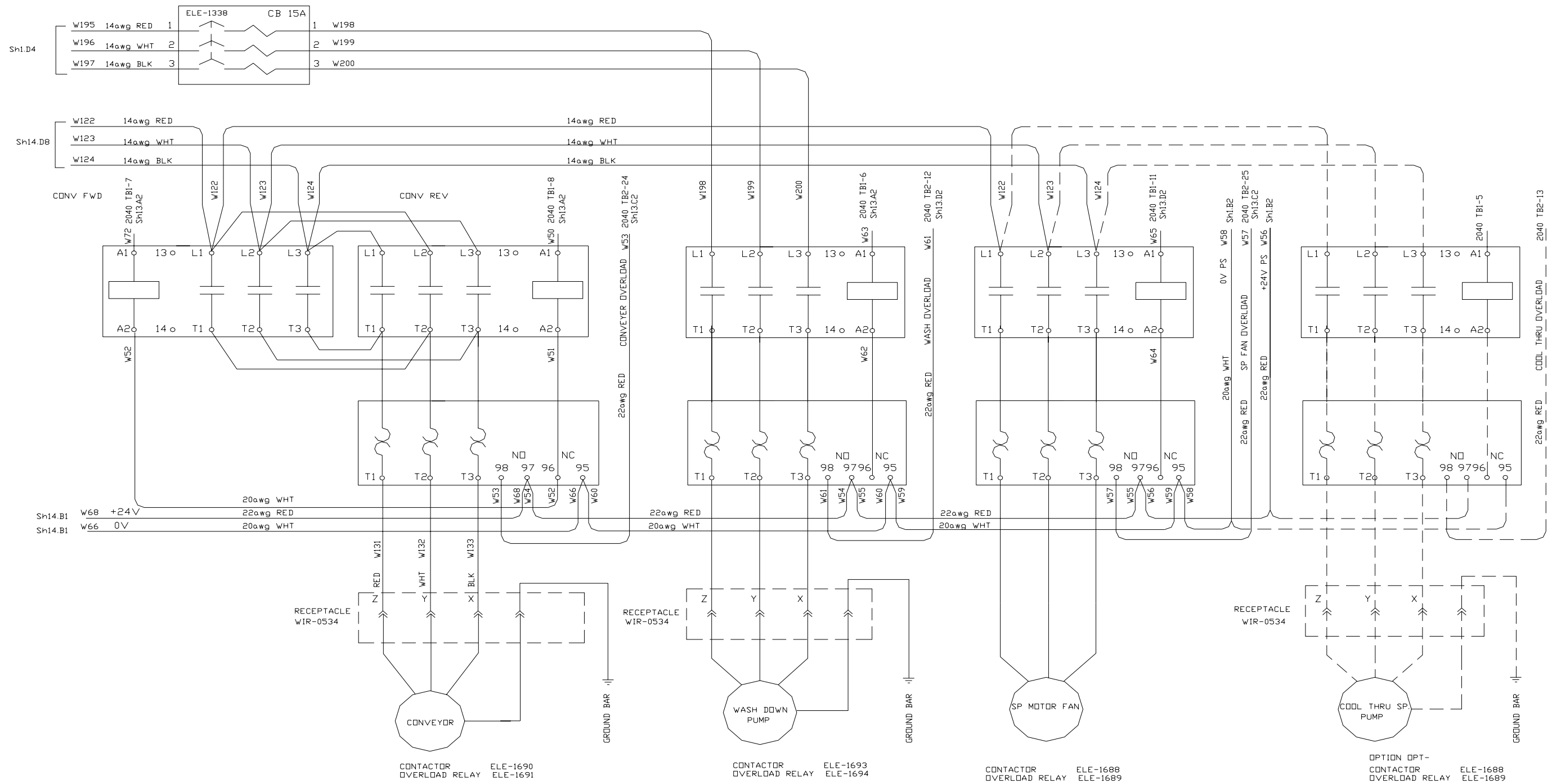

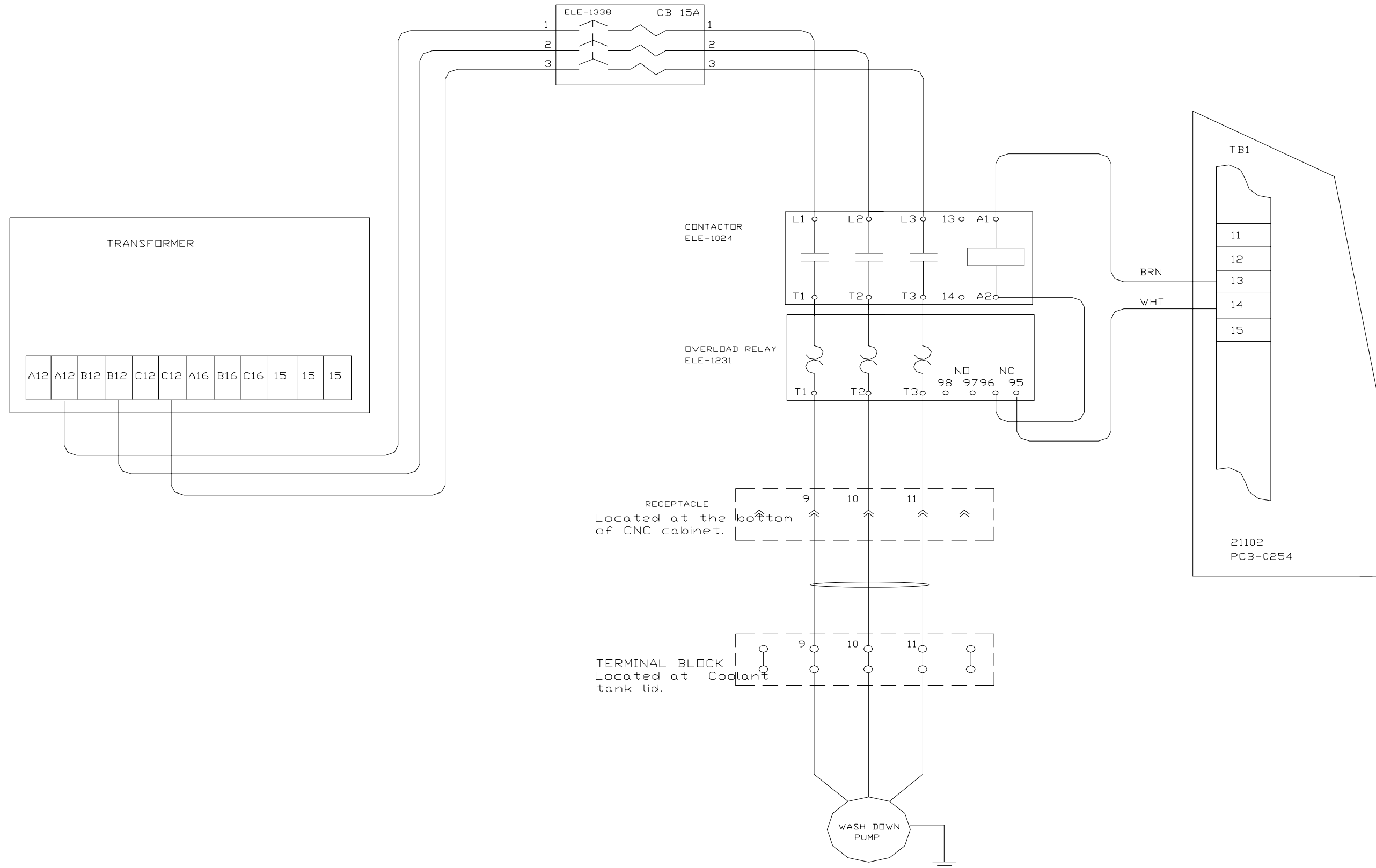

WRG_0693J_auger_washdown_wiring_diagram

1310 PIN LIST

- J1**
 - 120 VAC (INPUT)
 - PUMP
 - VALVE #1
 - VALVE #2
 - VALVE #3
 - 120 RETURN (INPUT)
 - E-STOP (INPUT)
 - CONTACTOR FOR AUGER
 - CONTACTOR FOR SPINDLE
 - RETURN FOR SPINDLE CONTACTOR
 - RETURN FOR AUGER CONTACTOR
 - AND PUMP STARTER
 - RETURN FOR VALVE COILS
- J2**
 - 1-3. AUGER MOTOR
 - 4-7. 220 VAC
- J3**
 1. START/STOP BUTTON
 - MODE SWITCH
 - M-FUNCTION INPUT
 - POT
 - +5V FOR POT
 - +5V
 - GROUND
 - EXTERNAL RESET
 - +5V
 - +5V (INPUT)
 - GROUND (INPUT)
 - EXTERNAL SLIDE HOLD OUTPUT
 - GROUND FOR EXTERNAL SLIDE HOLD
- J4**
 1. LEFT DOOR SWITCH (BLK)
 2. LEFT DOOR SWITCH (WHT)
 3. LEFT DOOR SWITCH (RED)
 4. LEFT DOOR SWITCH (GRN)
 5. RIGHT DOOR SWITCH (BLK)
 6. RIGHT DOOR SWITCH (WHT)
 7. RIGHT DOOR SWITCH (RED)
 8. RIGHT DOOR SWITCH (GRN)
 9. FRONT DOOR SWITCH (BLK)
 10. FRONT DOOR SWITCH (WHT)
 11. FRONT DOOR SWITCH (RED)
 12. FRONT DOOR SWITCH (GRN)

- K1 - SSR ELE-0070 TURN ON PUMP.
- K2 - SSR ELE-0070 VALVE 1.
- K3 - SSR ELE-0070 VALVE 2.
- K4 - SSR ELE-0070 VALVE 3.
- K6 - SSR ELE-0070 3 POLE RELAY 240V.
- K101 - SSR ELE-0101 SPINDLE RELAY

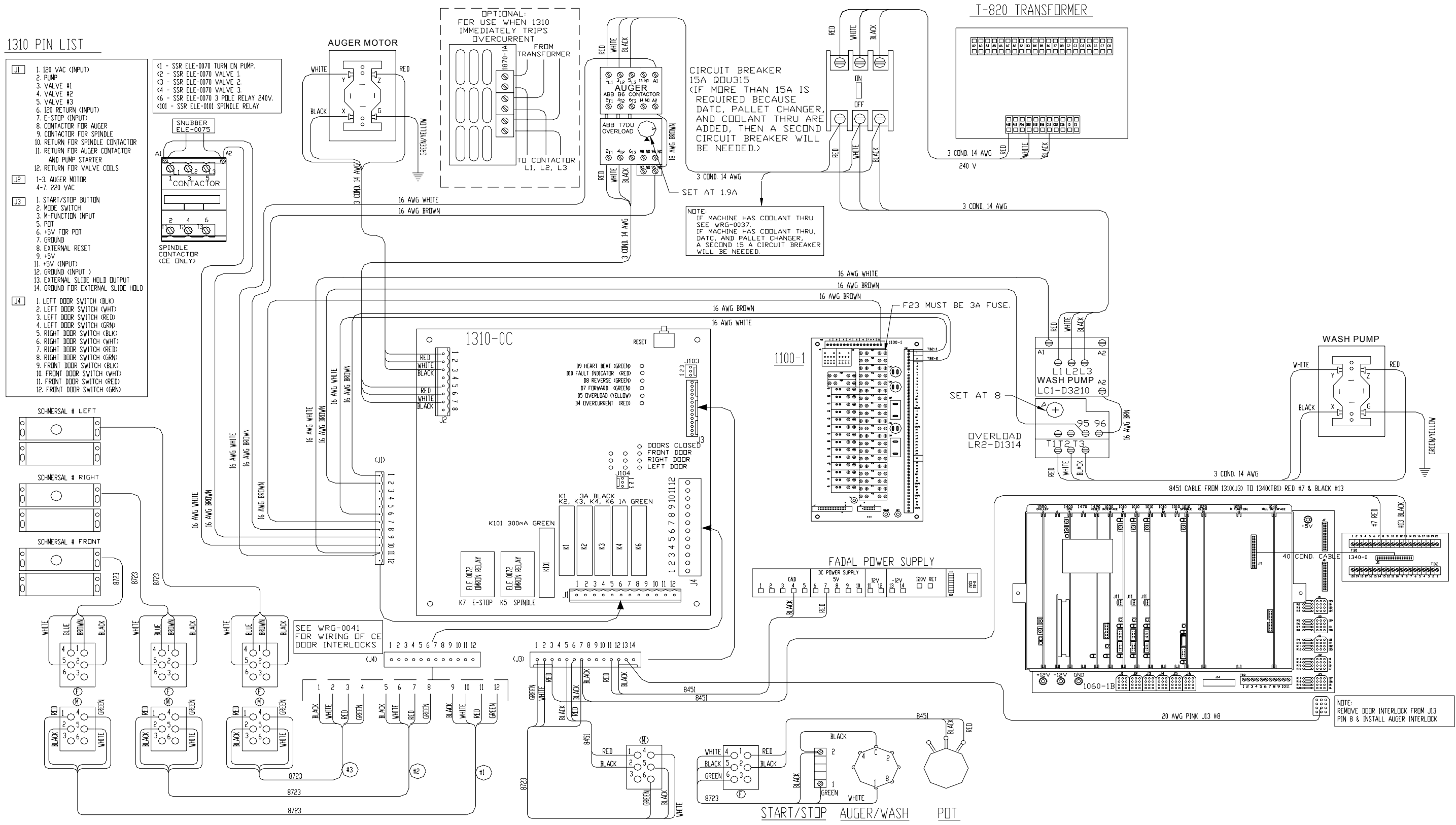

CIRCUIT BREAKER
15A QDU315
(IF MORE THAN 15A IS
REQUIRED BECAUSE
DATC, PALLET CHANGER,
AND COOLANT THRU ARE
ADDED, THEN A SECOND
CIRCUIT BREAKER WILL
BE NEEDED.)

NOTE:
IF MACHINE HAS COOLANT THRU
SEE WRG-0037.
IF MACHINE HAS COOLANT THRU,
DATC, AND PALLET CHANGER,
A SECOND 15A CIRCUIT BREAKER
WILL BE NEEDED.

F23 MUST BE 3A FUSE.

NOTE:
REMOVE DOOR INTERLOCK FROM J13
PIN 8 & INSTALL AUGER INTERLOCK

