

# **SECTION 6**

## **Pendant**

# WRG\_0020D\_pendant\_wiring\_1990\_1\_board

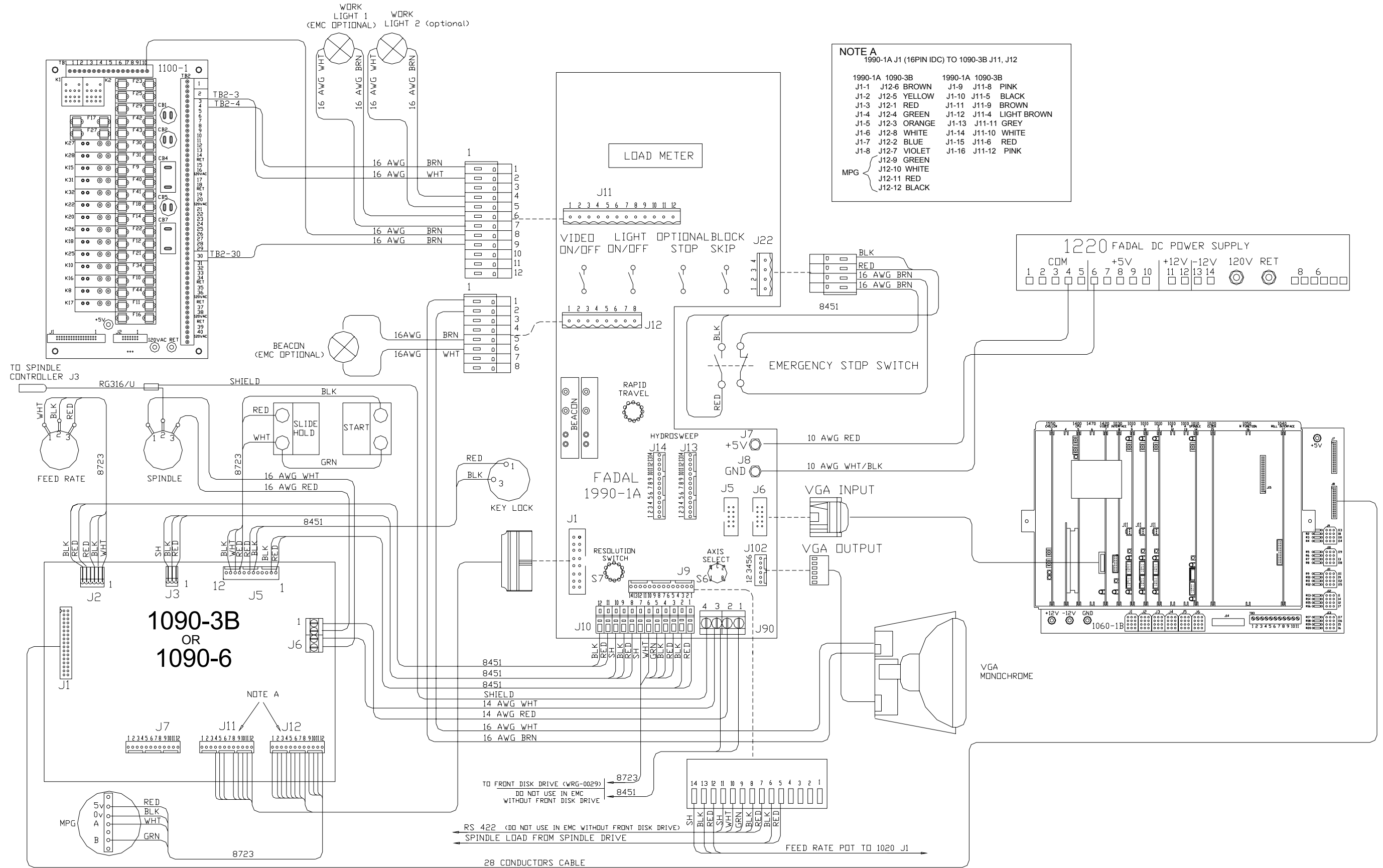

# WRG\_0021B\_1990\_2\_board\_32mp

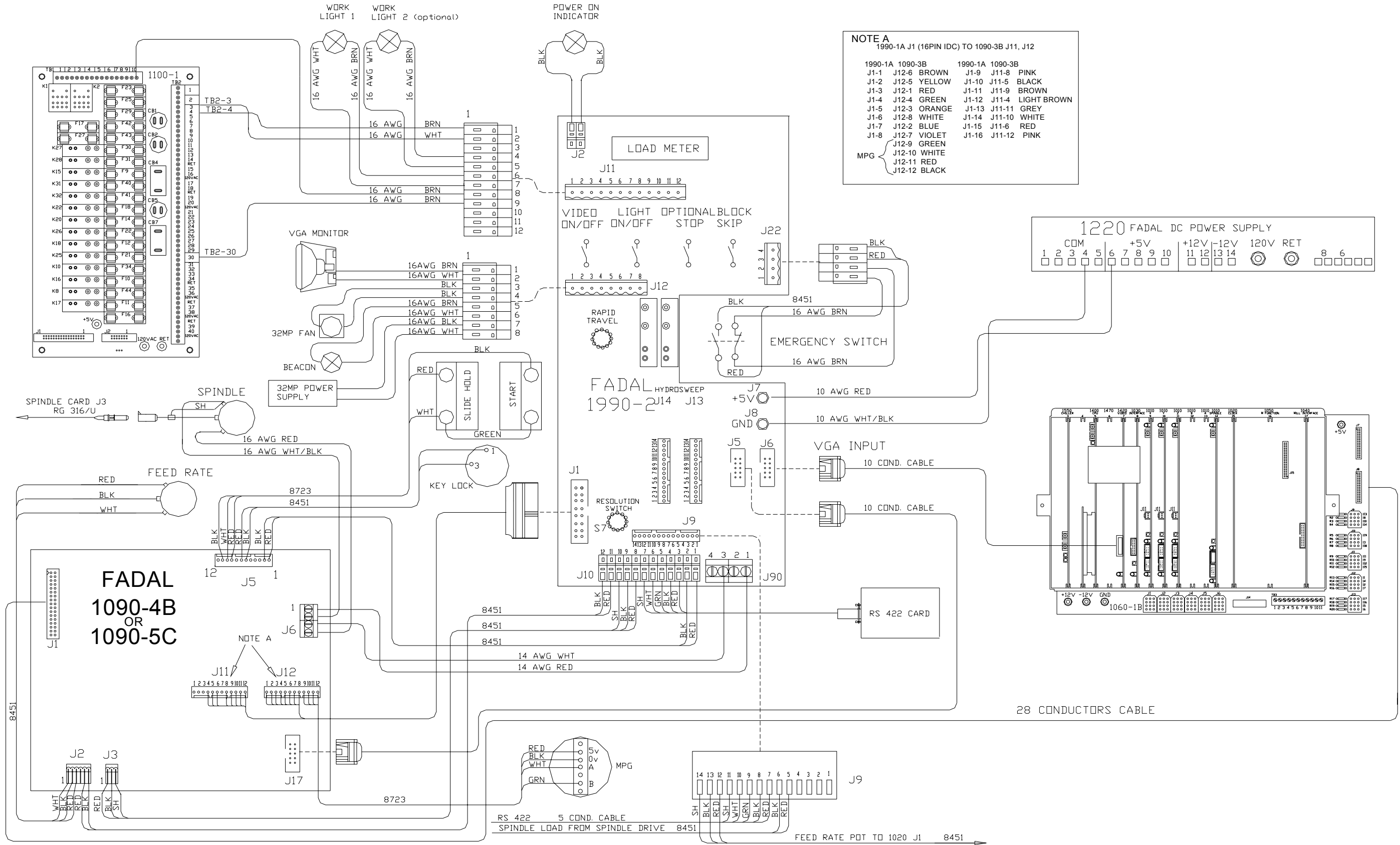

# WRG\_0025B\_pendant\_wiring\_1990\_1\_board\_color\_vga

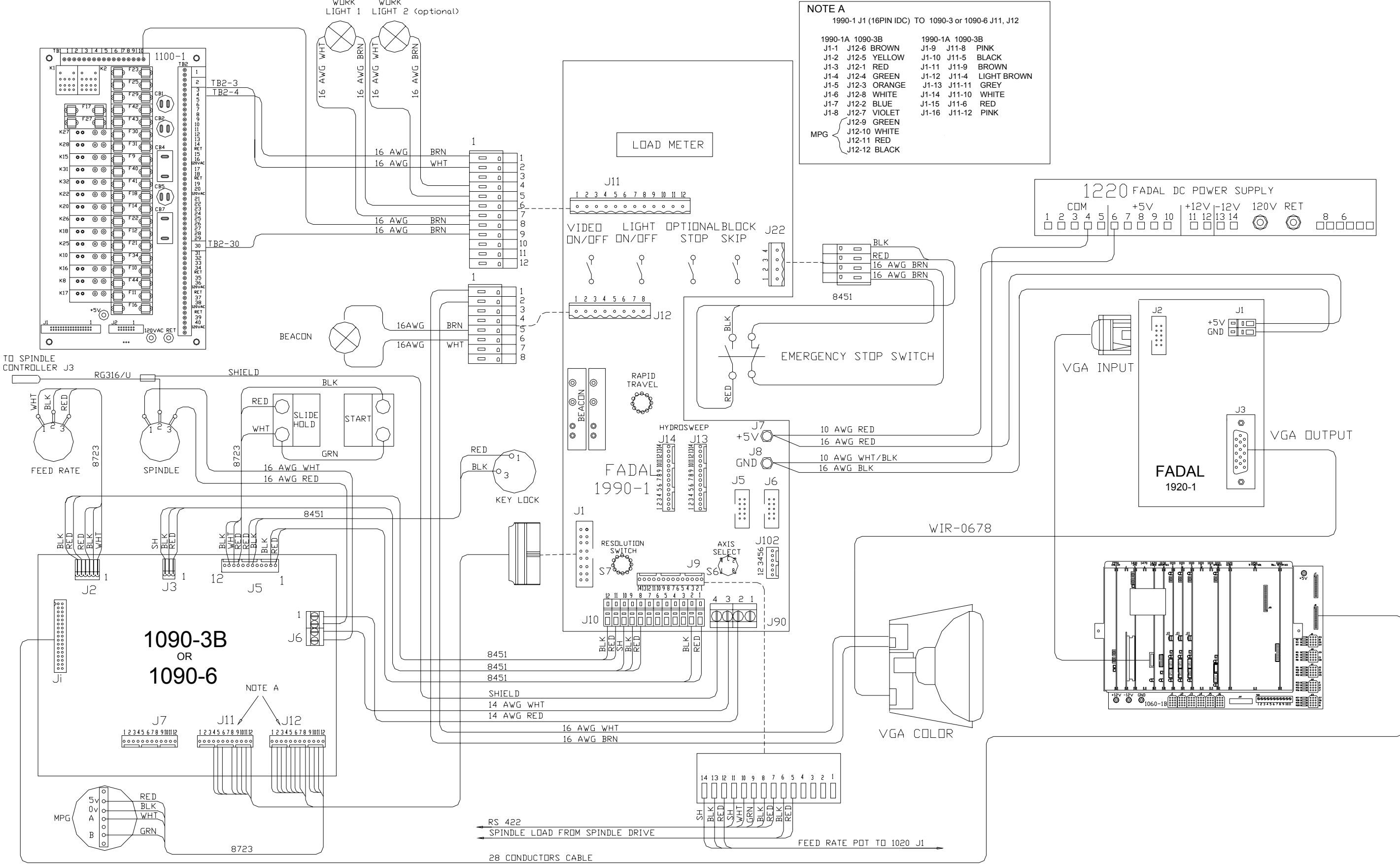

CNC 88/MULTI PROCESSOR

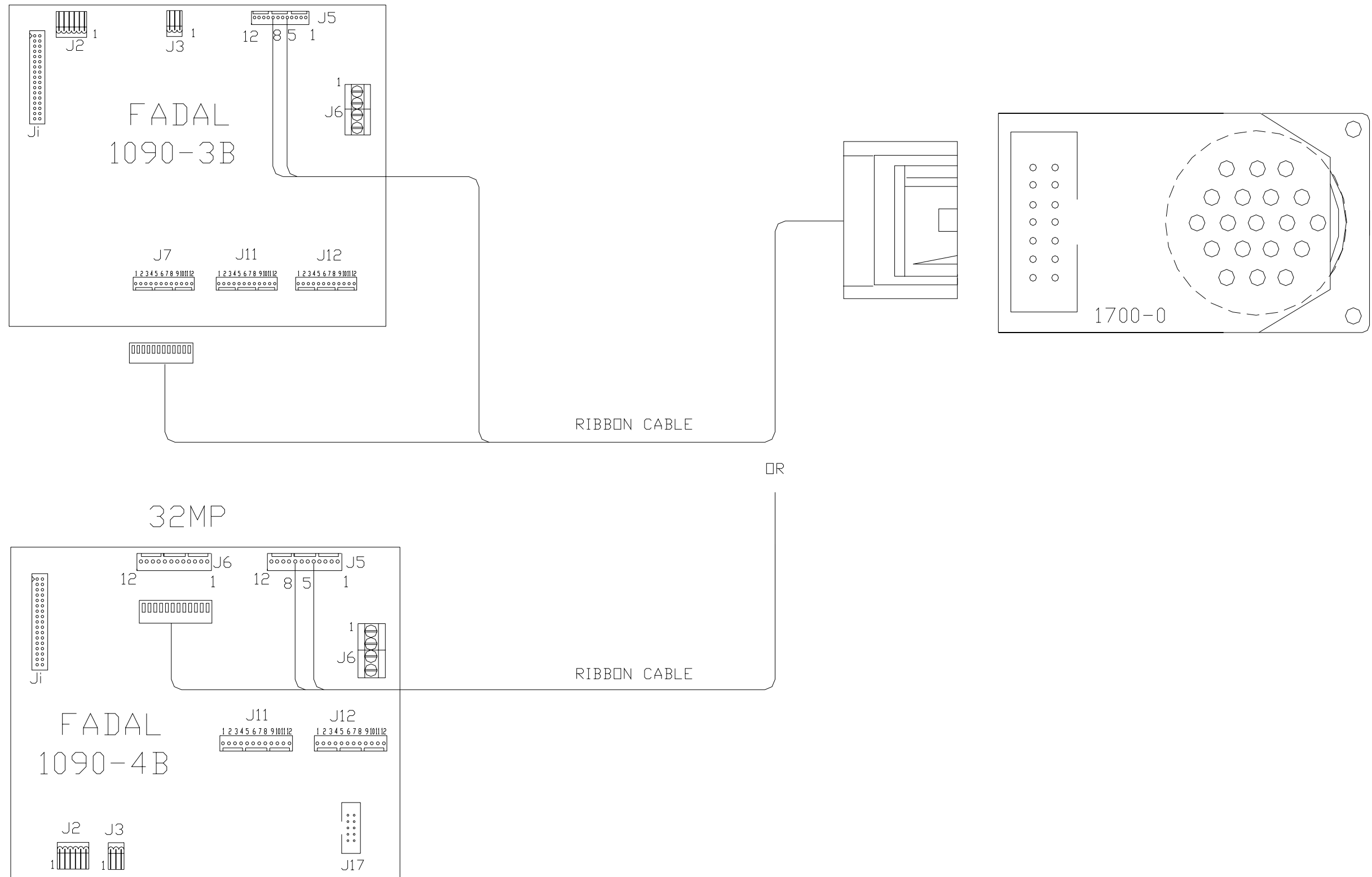

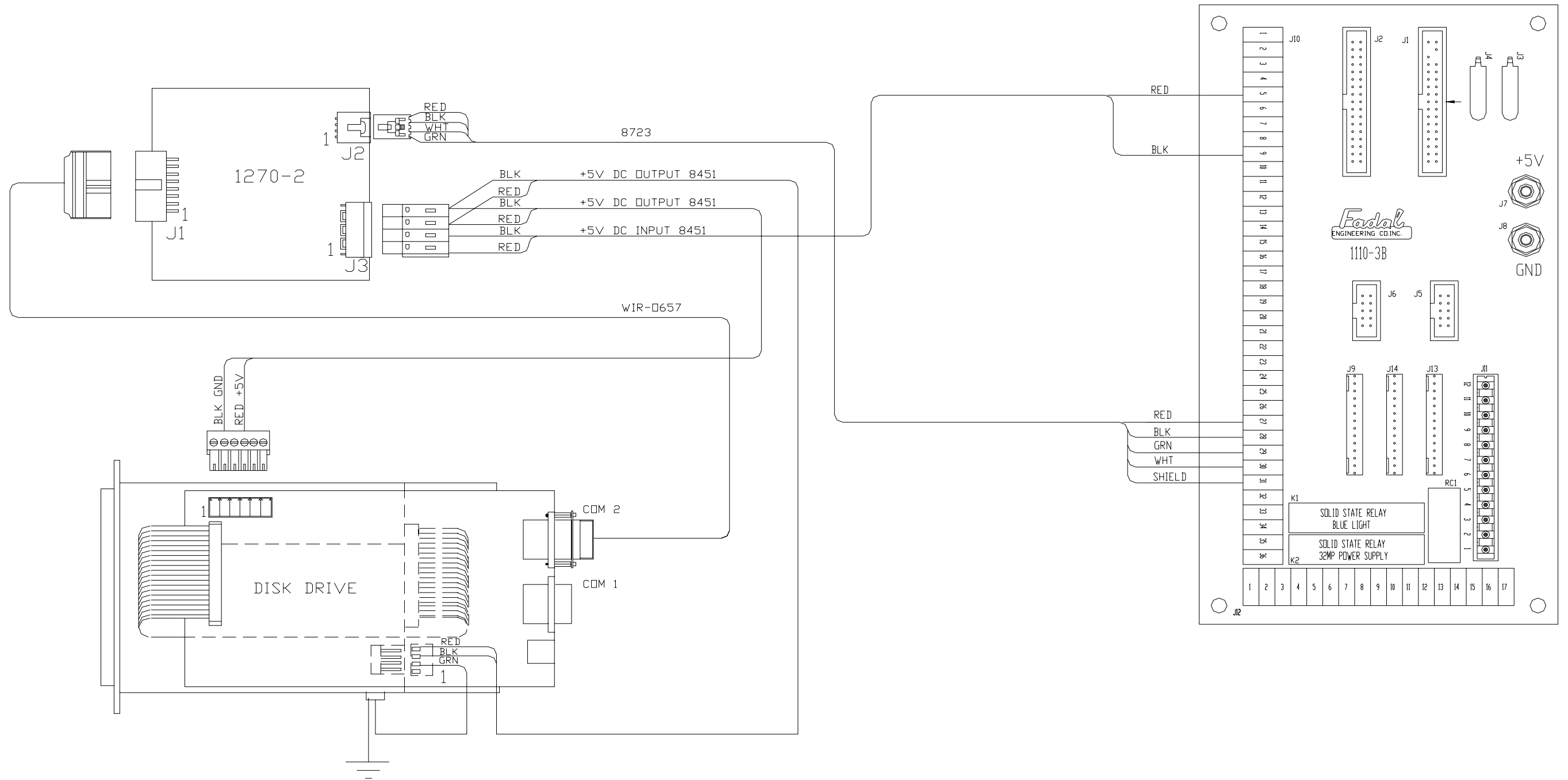

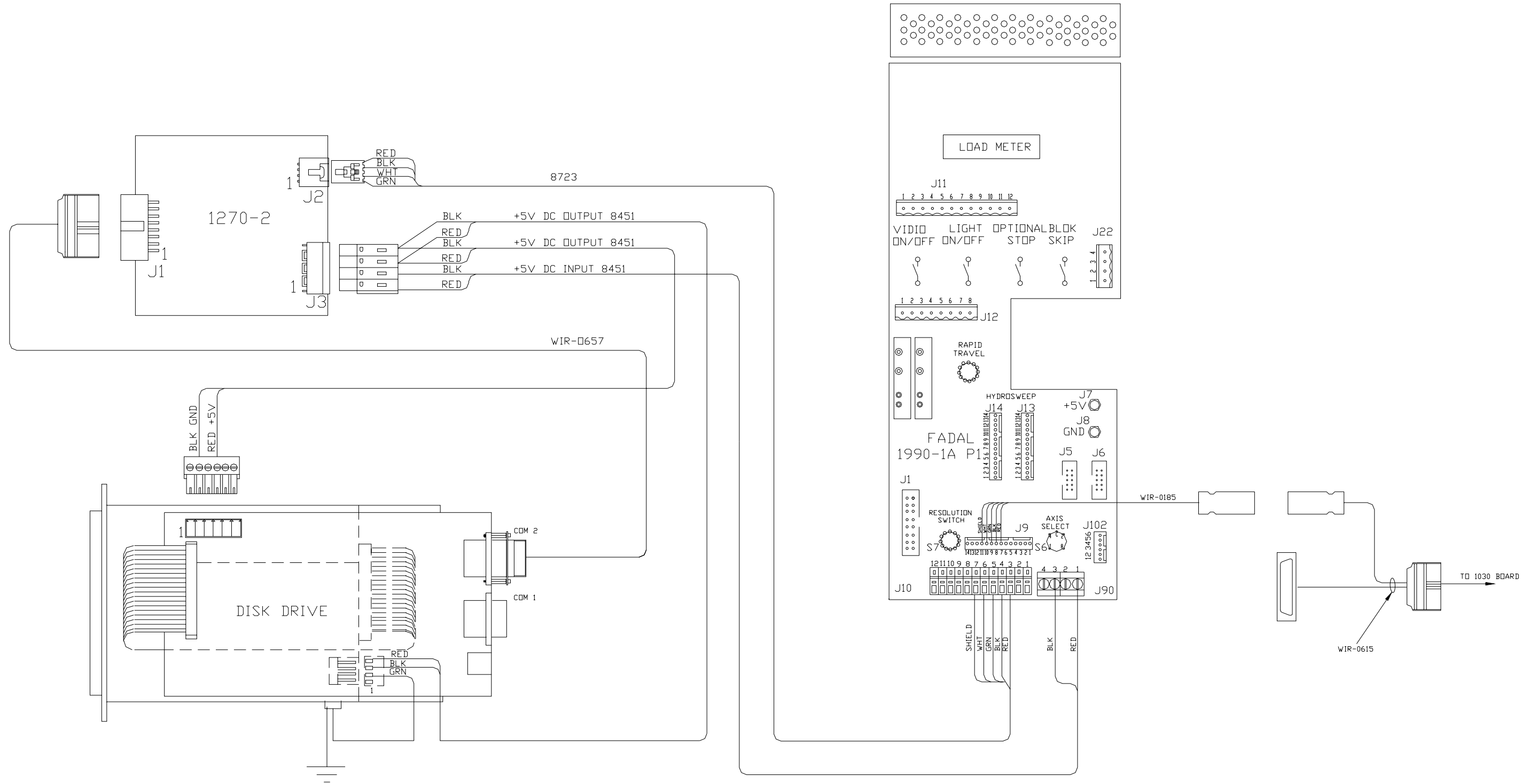

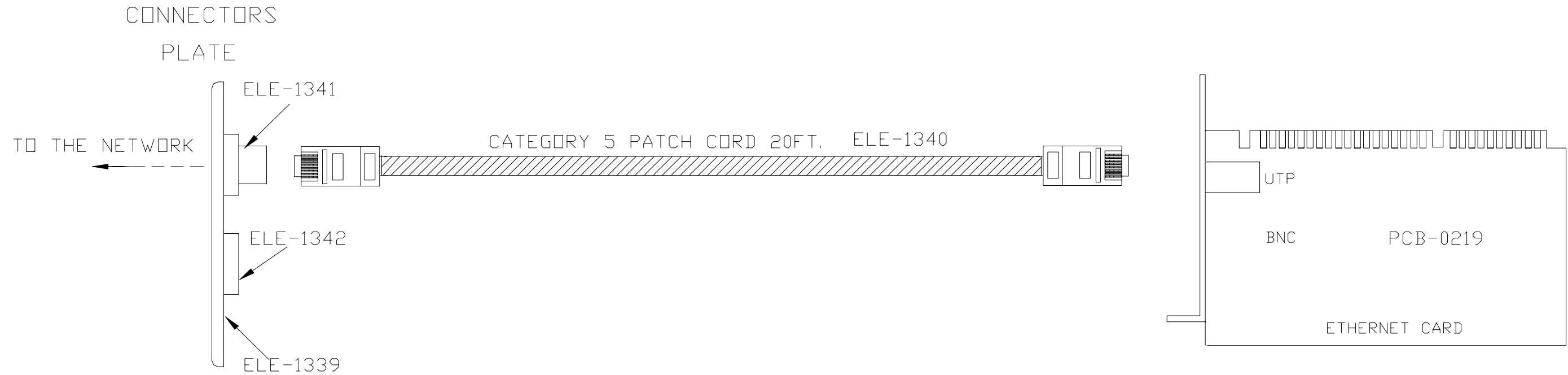

NOTE:

1. Install the Ethernet card into the PC chassis frame in 32MP control.
2. Install the connectors plate on the right bottom side of CNC cabinet for standard sheet metal and on the left bottom side of CNC cabinet for SLANT 98.
3. If the PC mother board is ETHERNET ready, connect the ETHERNET cables to the appropriate terminals on mother board.



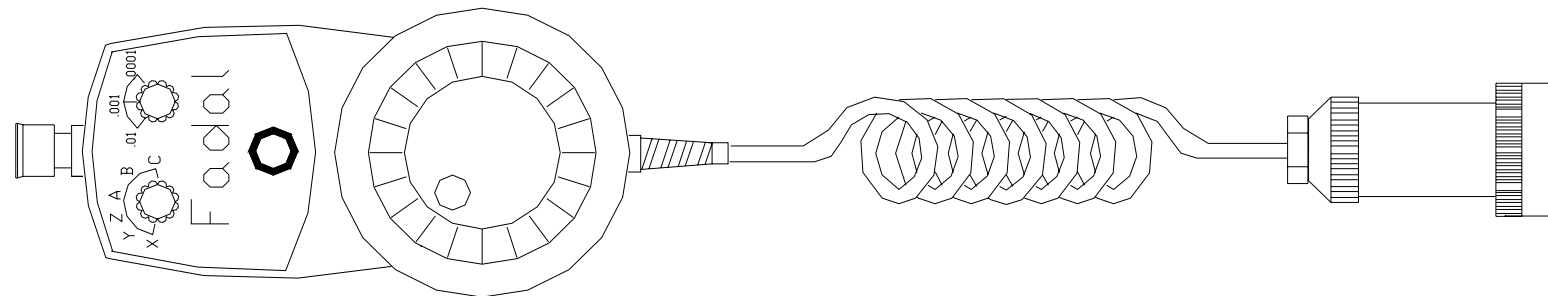
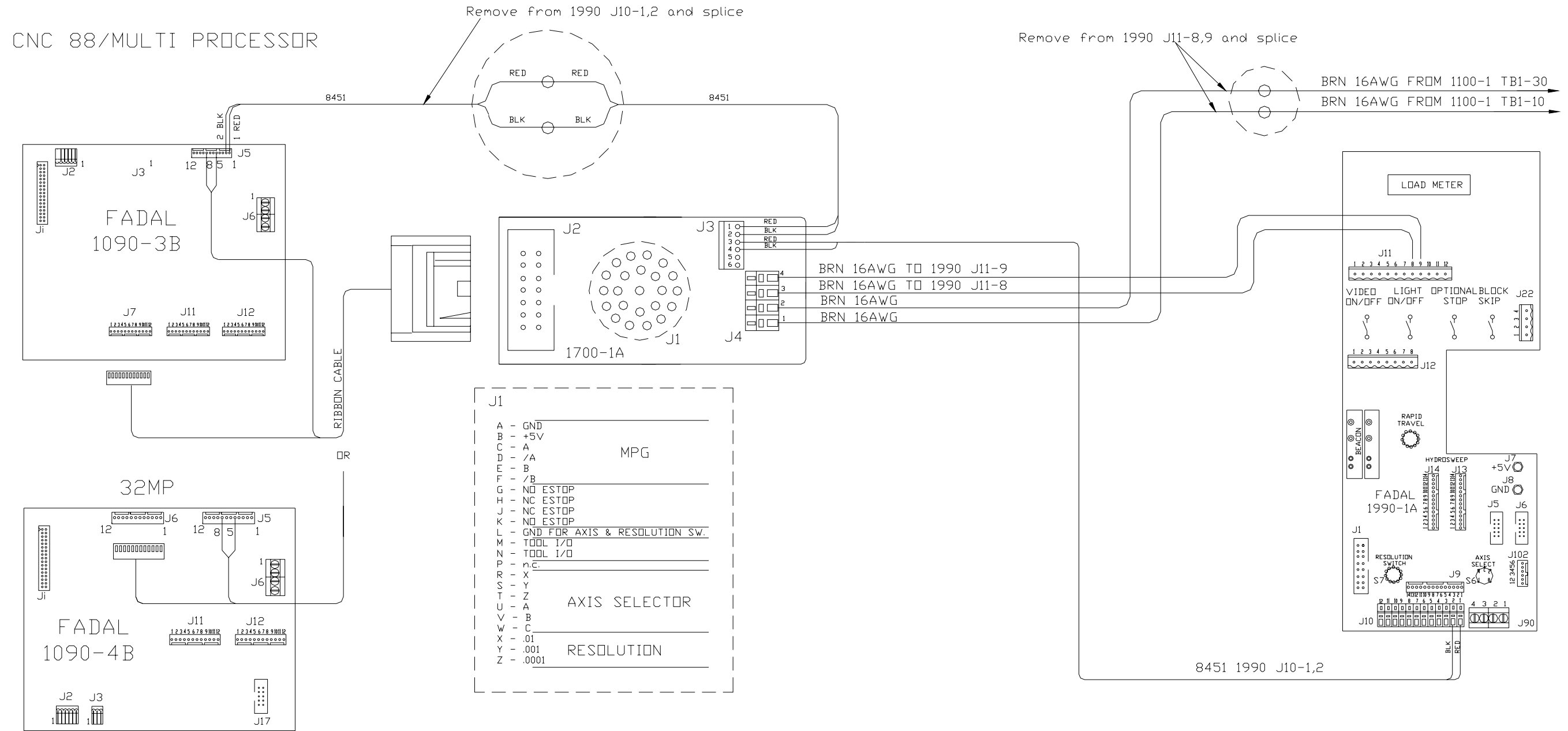

# WRG\_0057B\_pendant\_wiring\_LCD\_monitor

