

SECTION 9

EMC

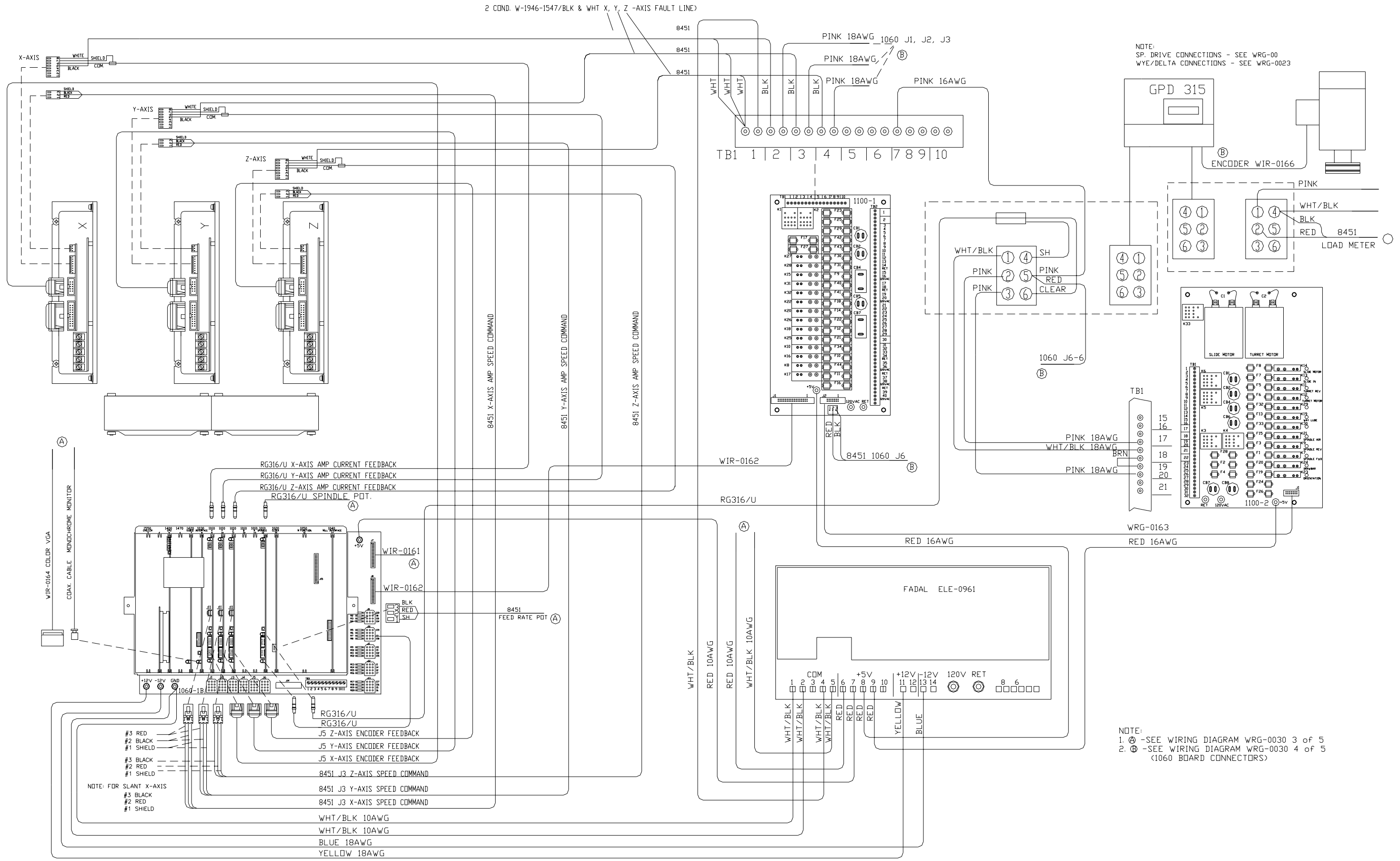

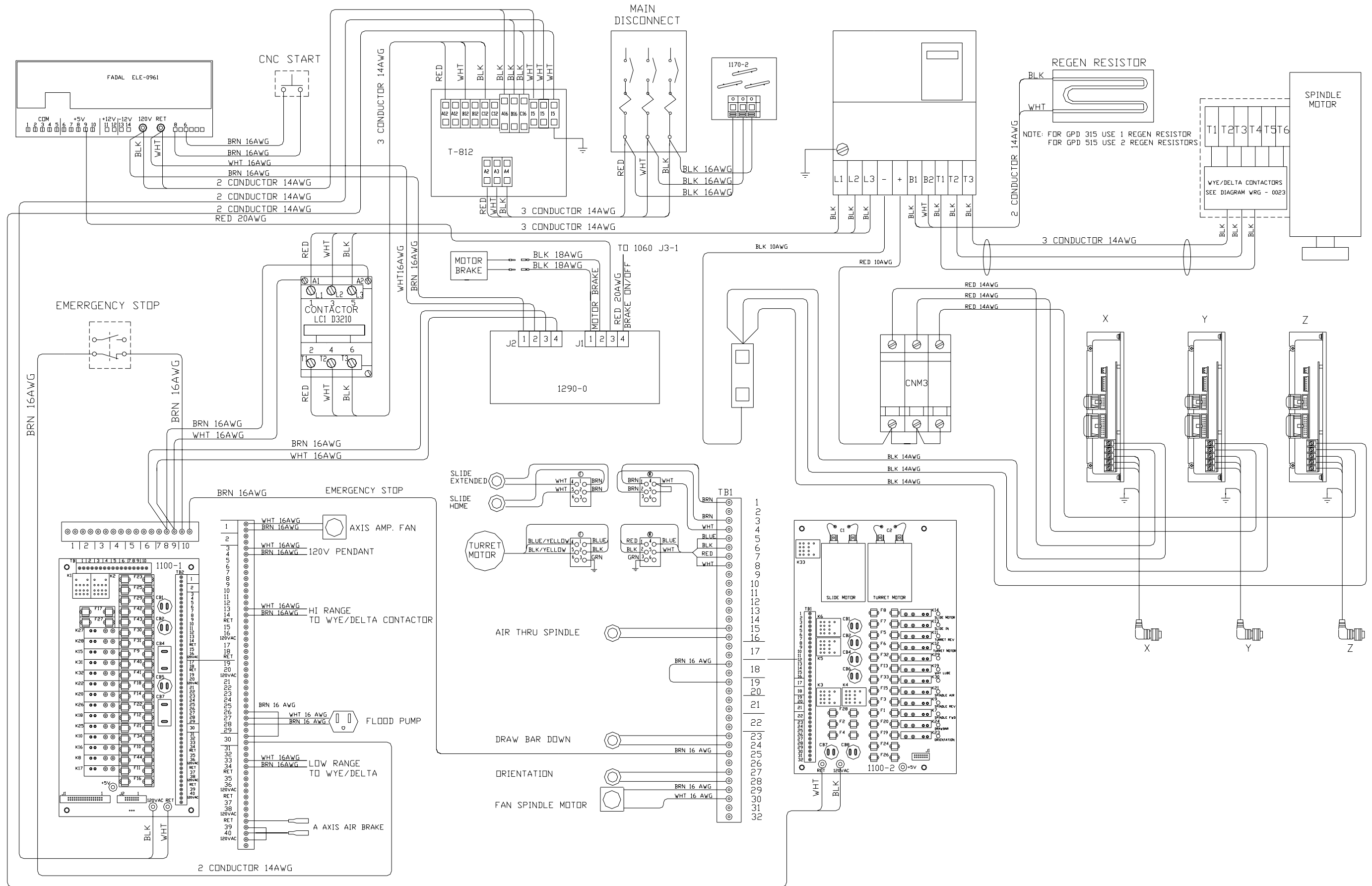

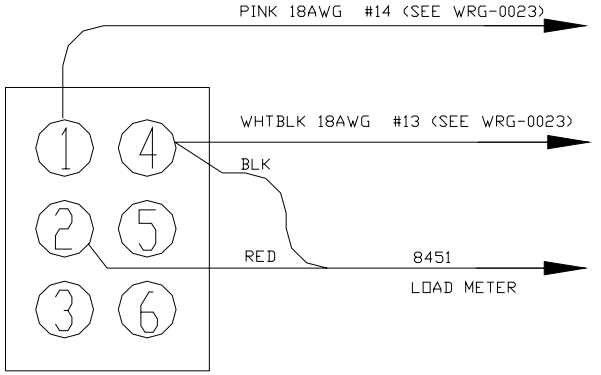
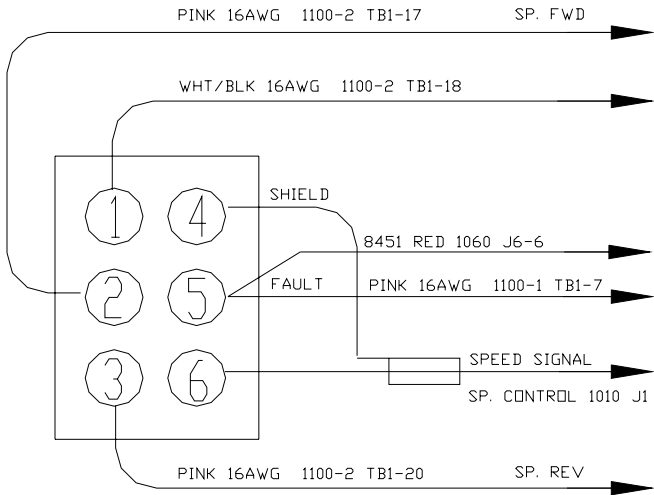
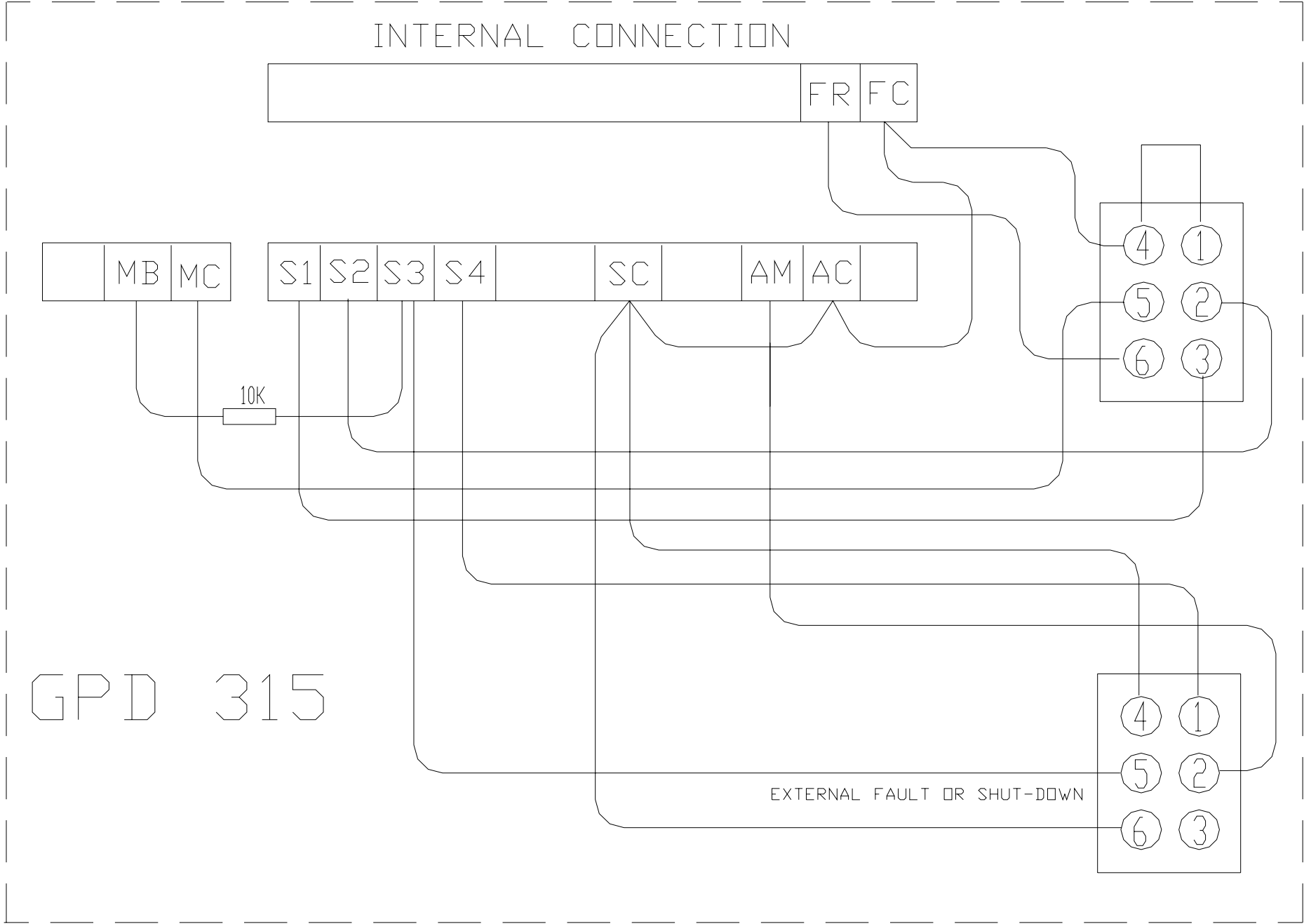

INTERNAL CONNECTION

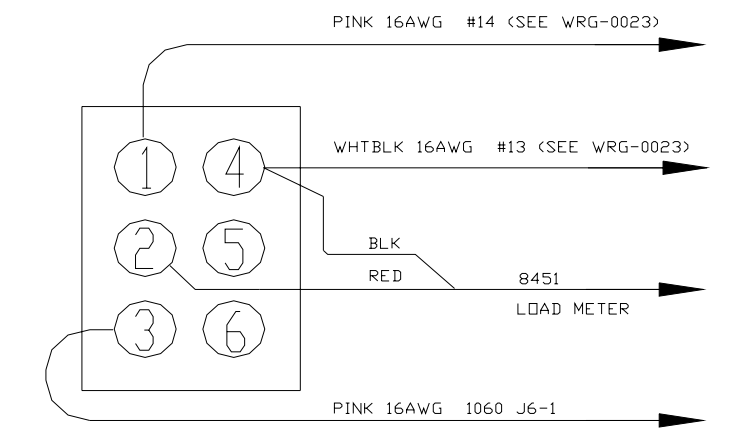
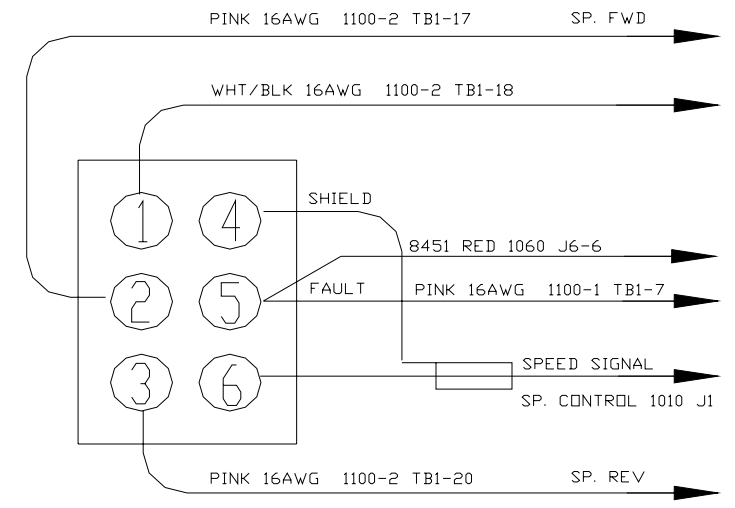
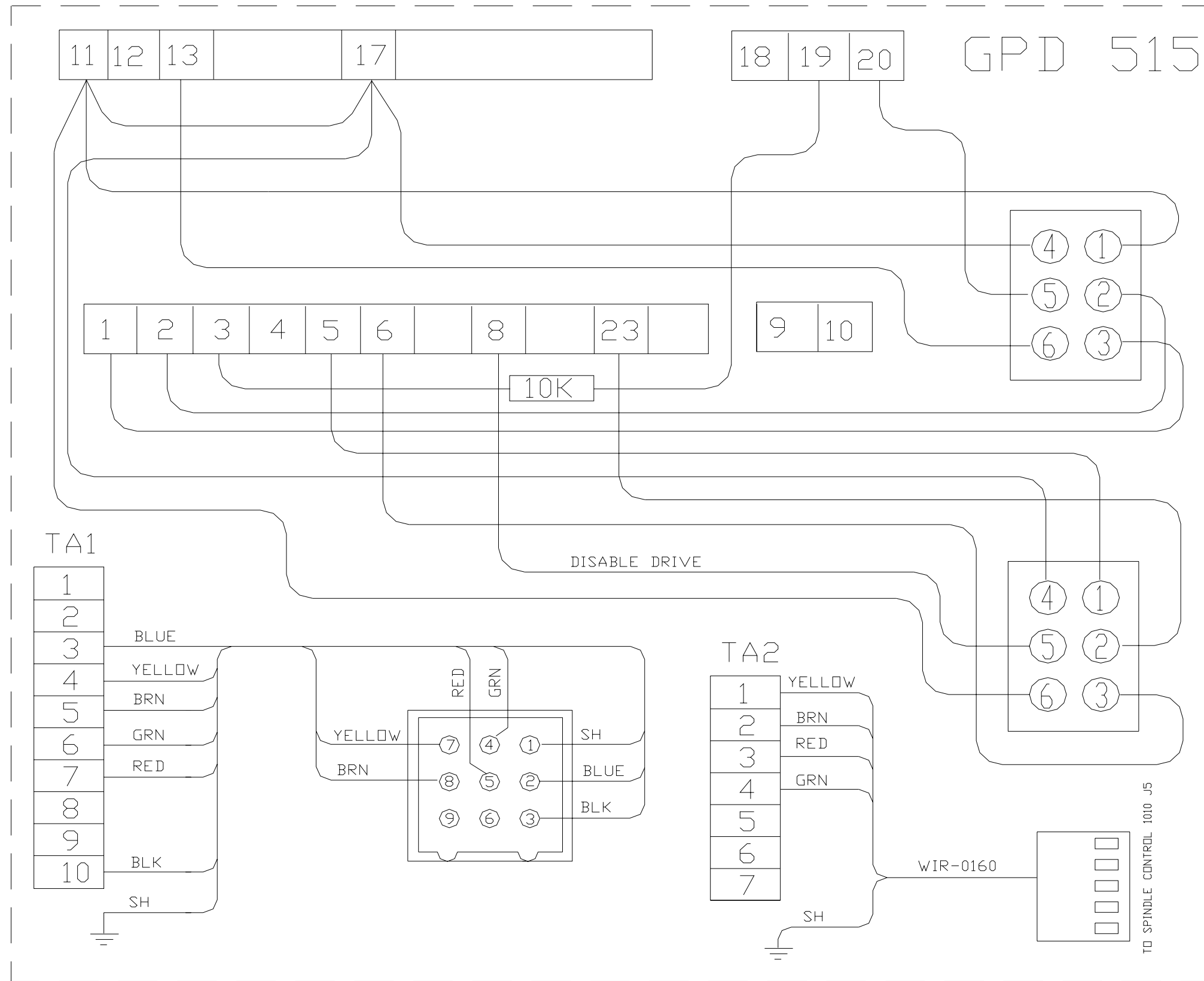

Wrg_0053A_emc_disk_drive_harness

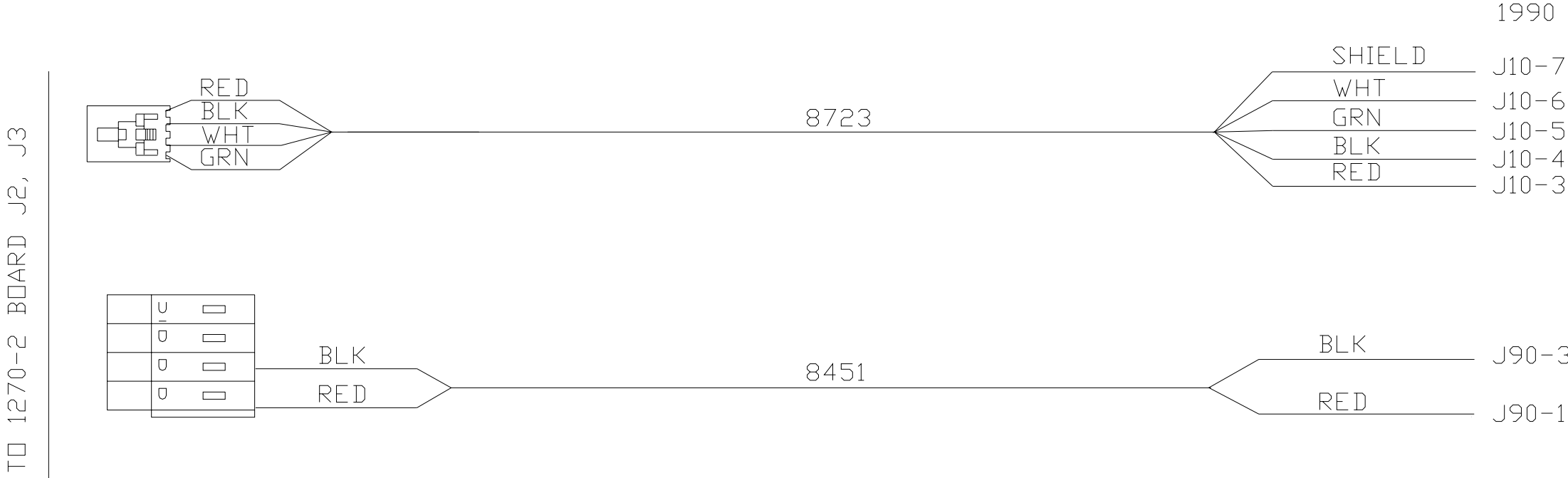

WRG_0041F_ce_door_lock_2030-0A_wiring_diagram_1of3

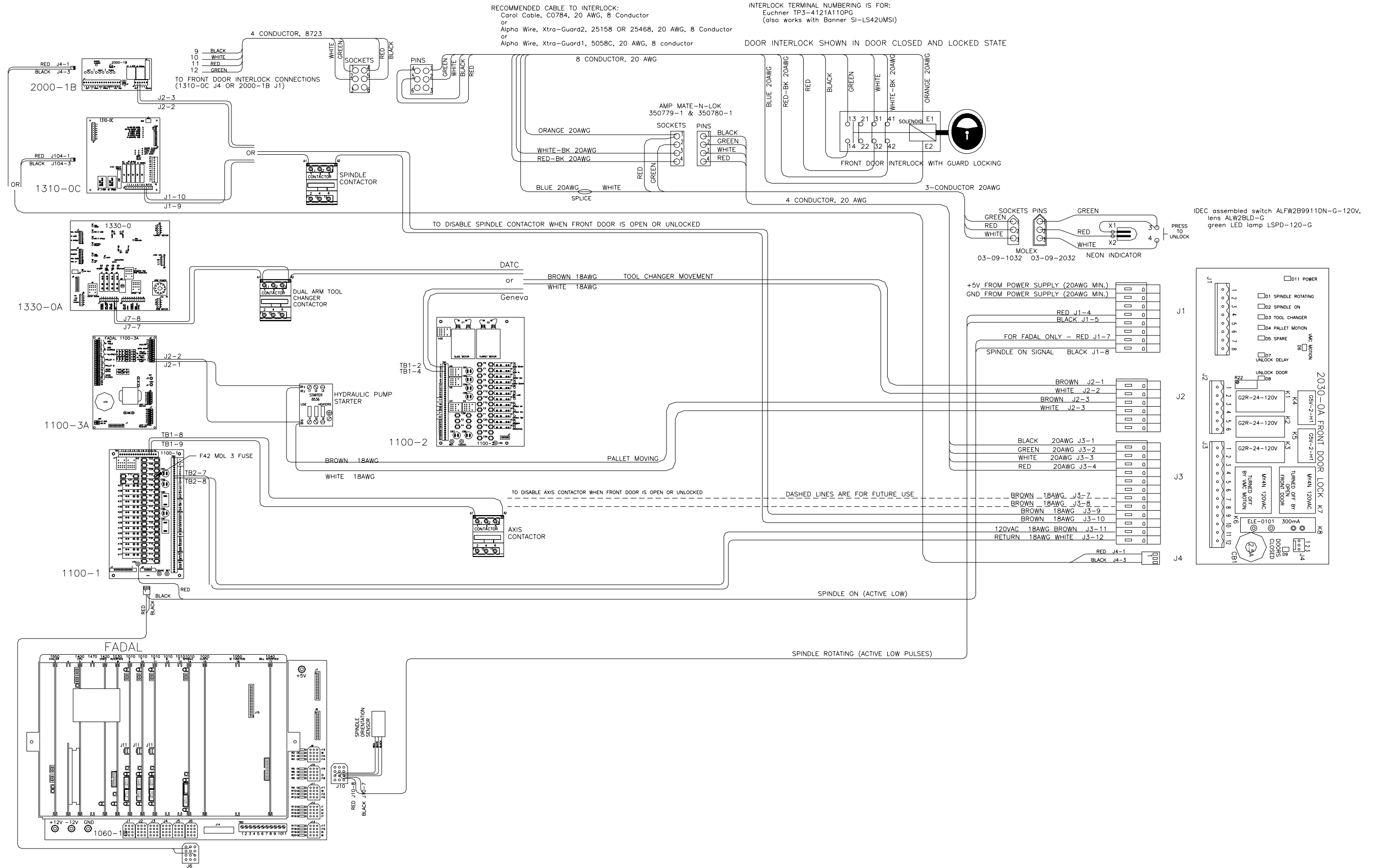

WRG_0041F_ce_door_lock_2030-0A_wiring_diagram_2of3

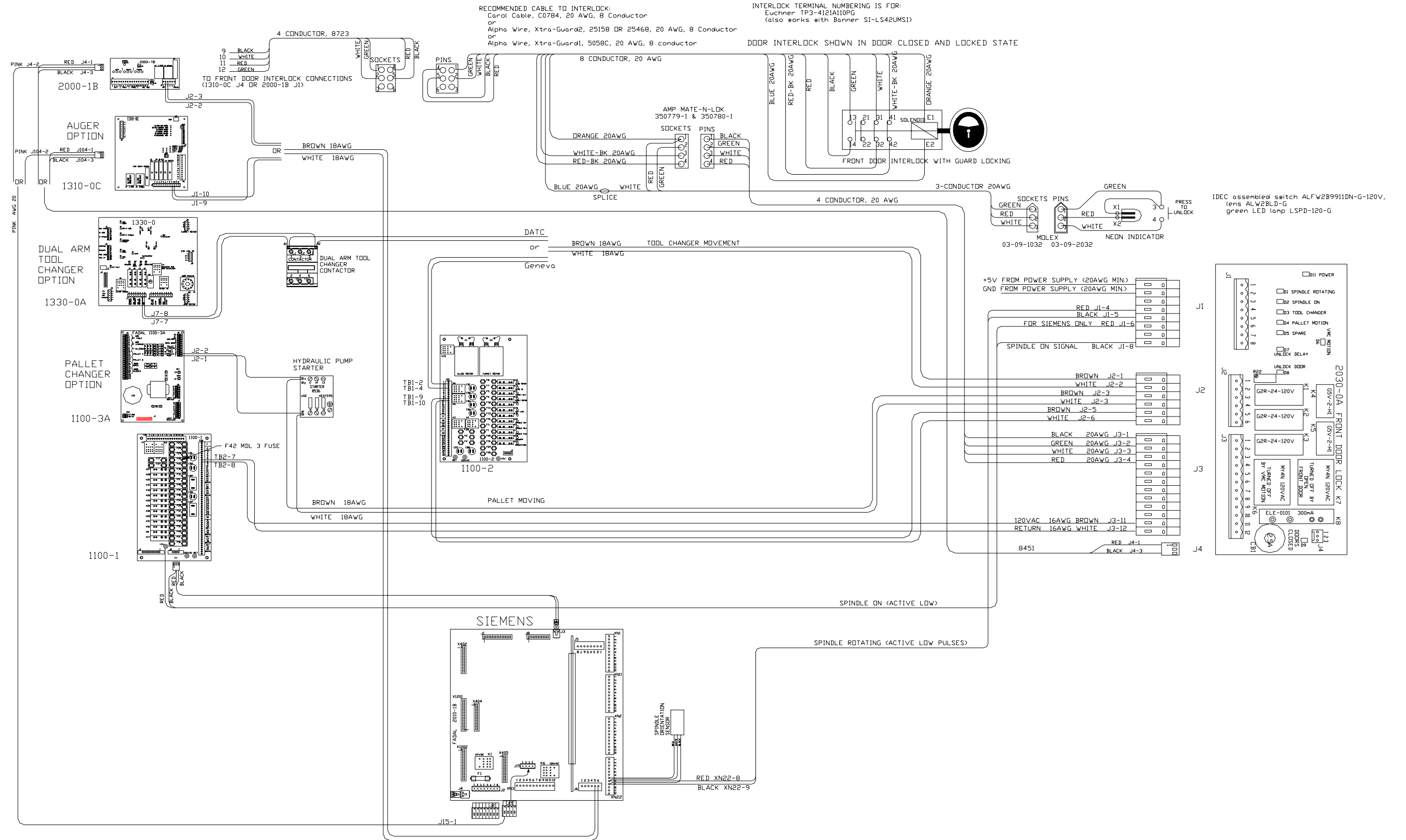

WRG_0041F_ce_door_lock EMC 2030-0A wiring diagram_3of3

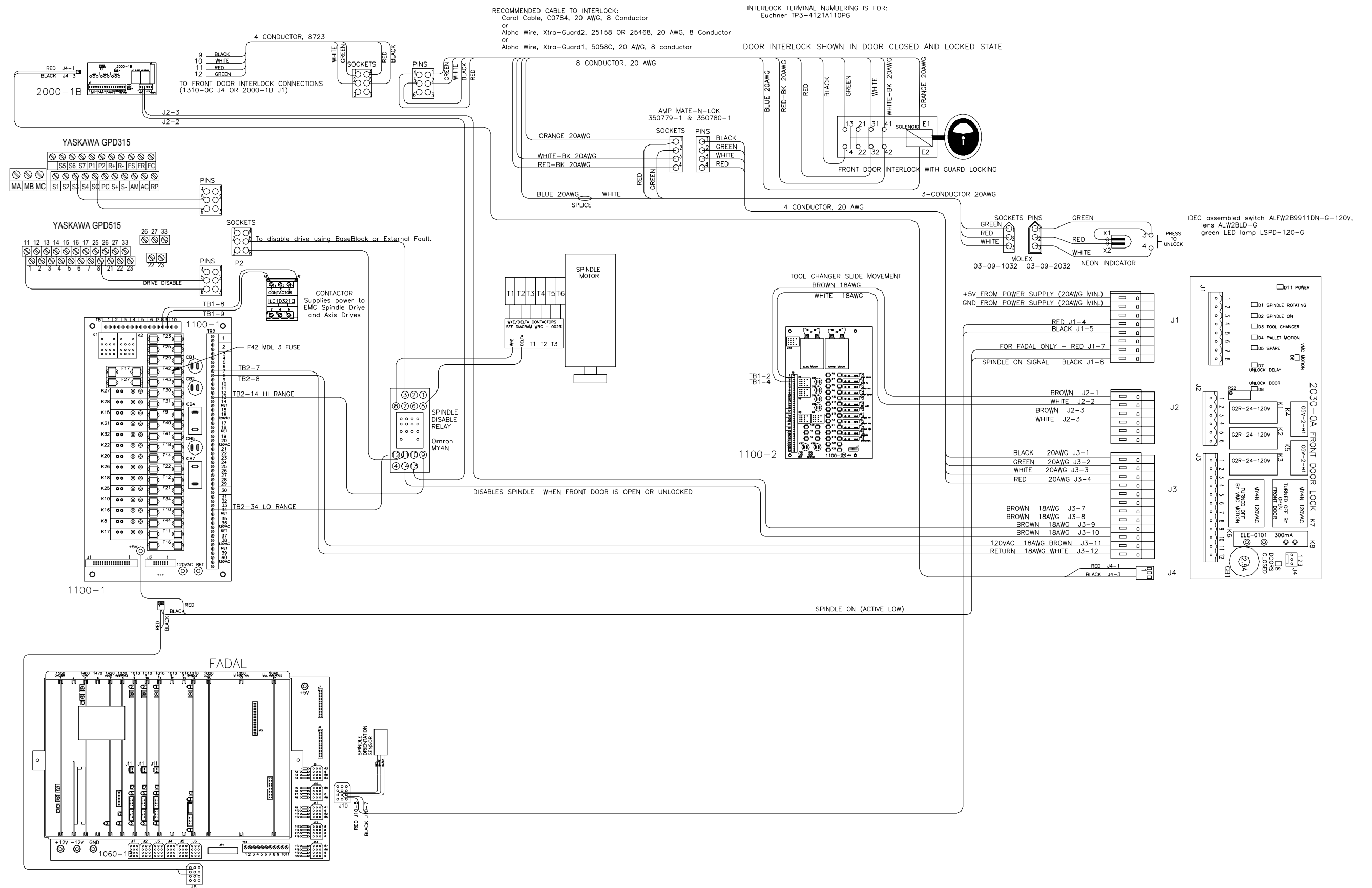

WRG_0049B_emc_4th_axis

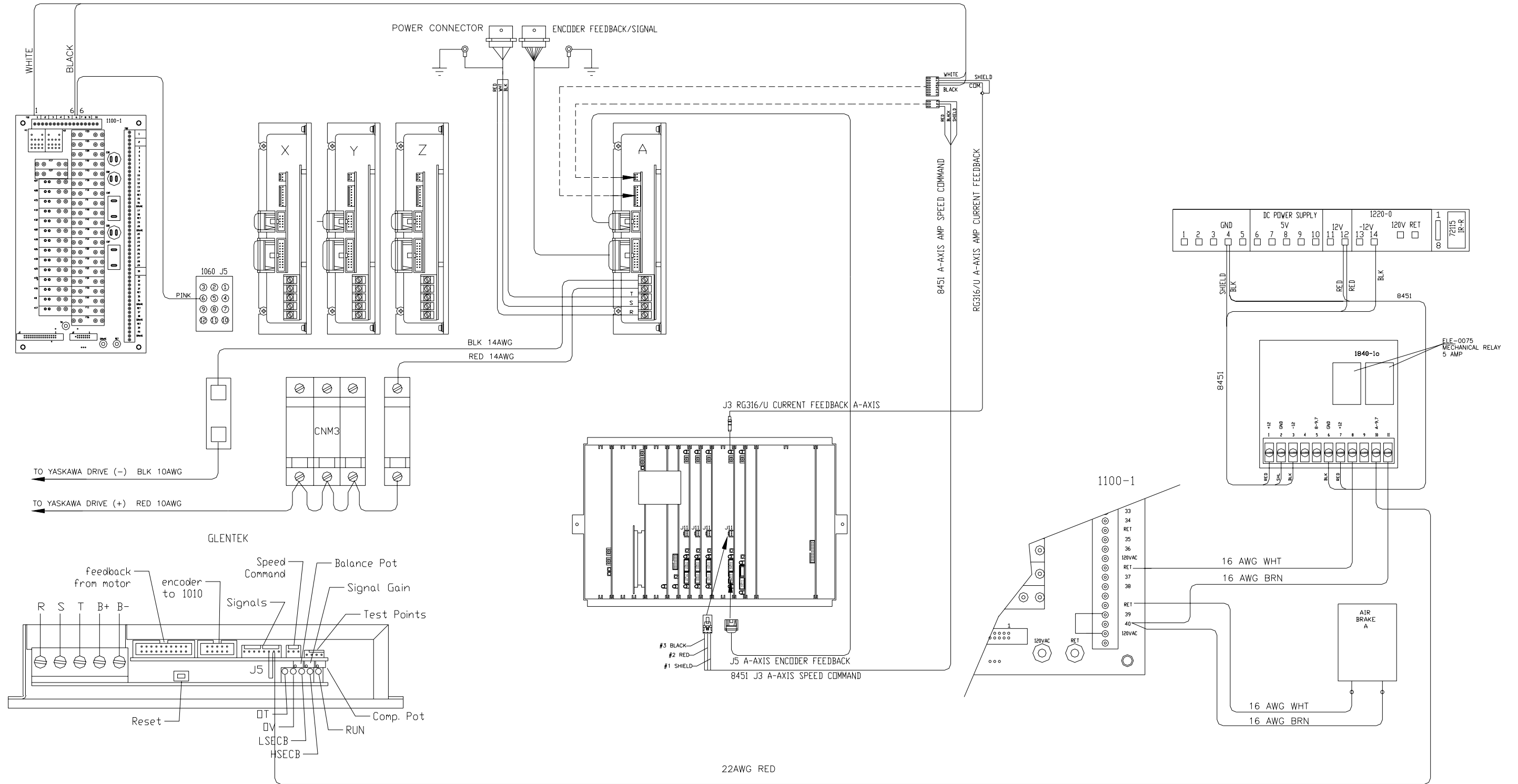

NOTE:

1. INSTALL FUSE F11 (AGC 2) AND SOLID STATE RELAY K17 (GREEN) ON 1100-1 BOARD.
2. USE AMPLIFIER AMP-0029 FOR VH65.
3. INSTALL JUMPER ON 4th AXIS AMPLIFIER IN J5 BETWEEN +LIMIT & -LIMIT (22 AWG RED).