

SECTION 10

Chip Conveyor

WRG_0045B_CE_wiring_Hennig_Chip_Conveyor

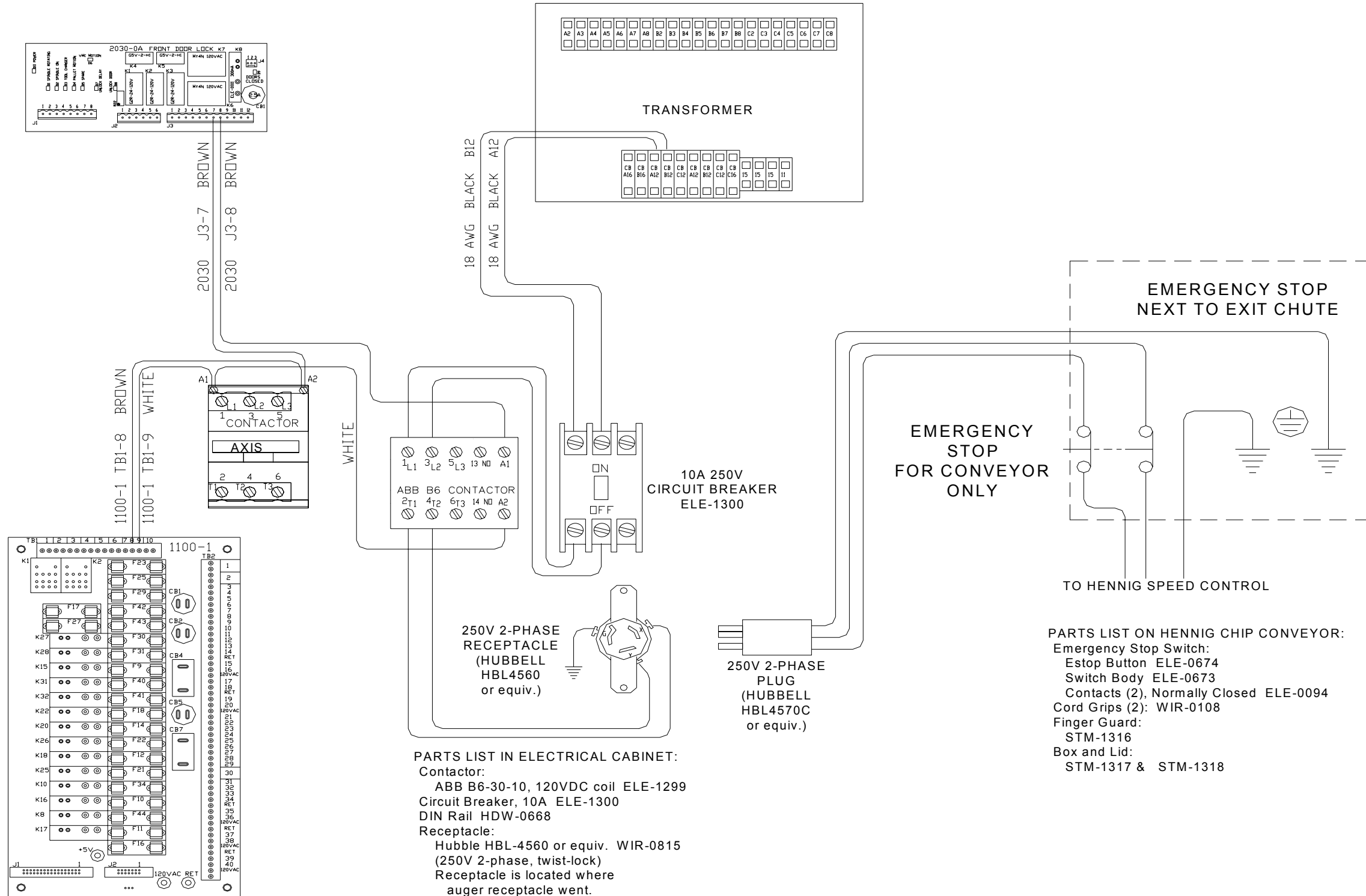

WRG_0062A_US wiring_Hennig_Chip_Conveyor

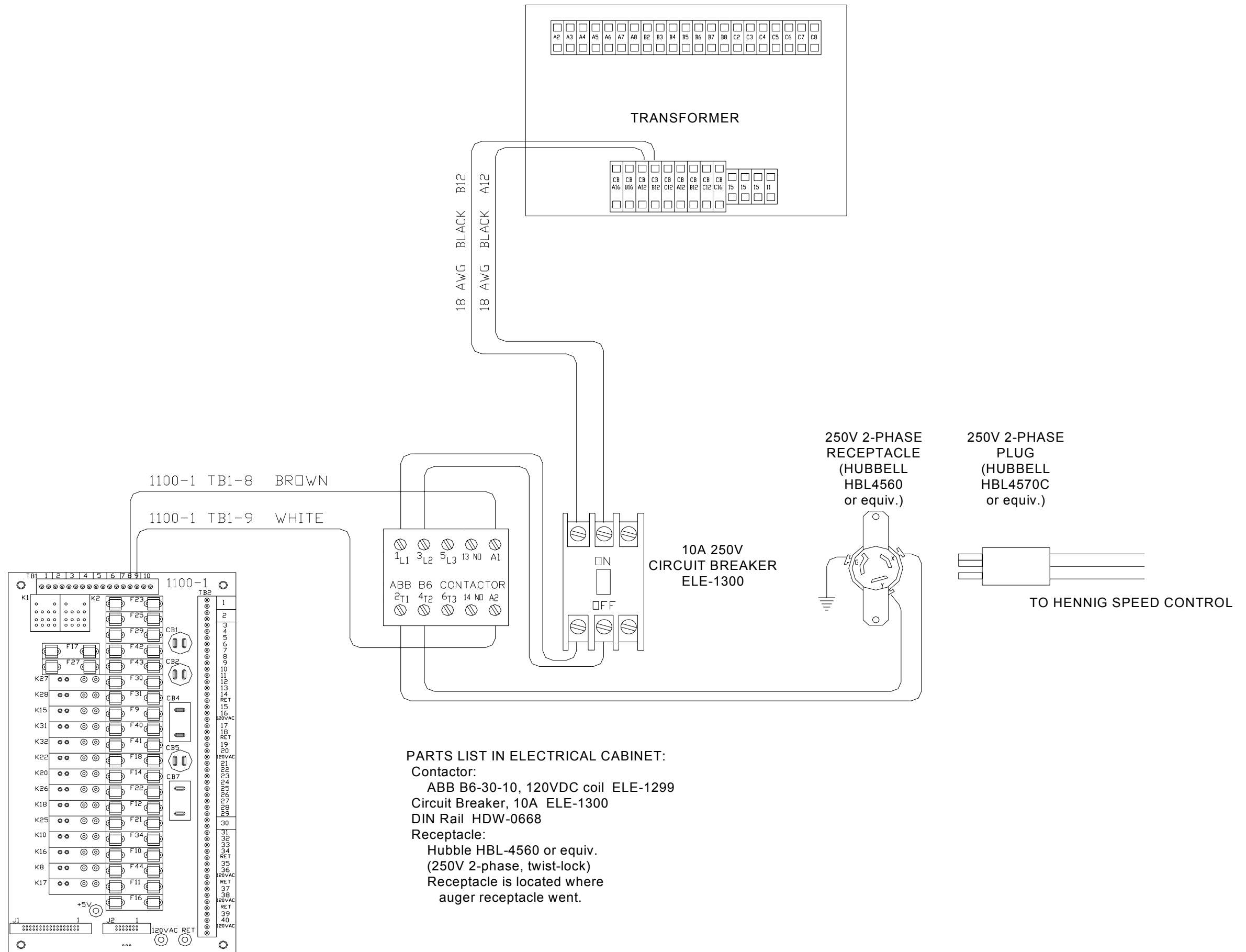

PARTS LIST IN ELECTRICAL CABINET:

- Contactor:
ABB B6-30-10, 120VDC coil ELE-1299
- Circuit Breaker, 10A ELE-1300
- DIN Rail HDW-0668
- Receptacle:
Hubbell HBL-4560 or equiv.
(250V 2-phase, twist-lock)
Receptacle is located where
auger receptacle went.

WRG_0063A_CE_wiring_Siemens_Hennig_Chip_Conveyor

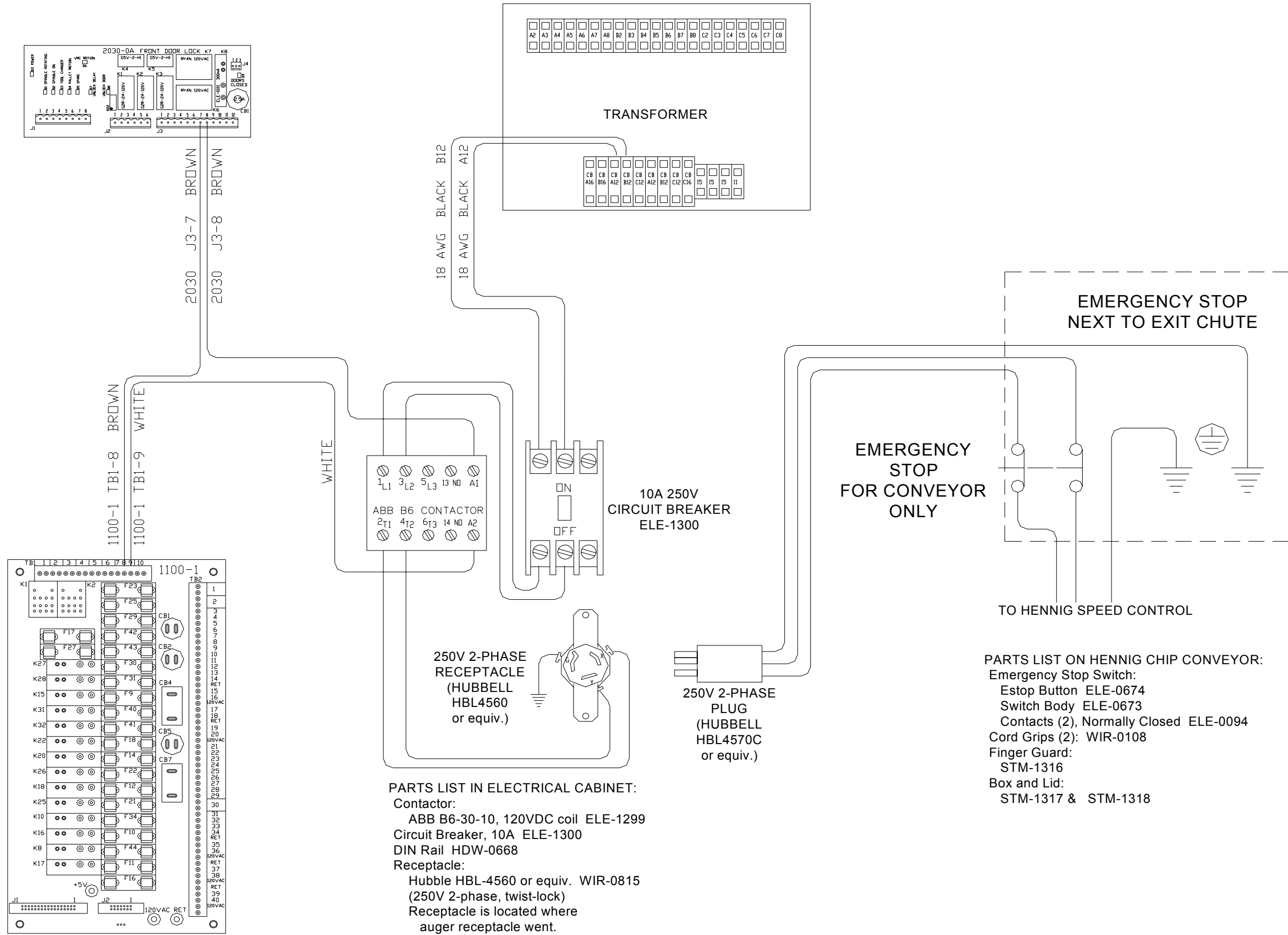

WRG_0083A_sht1of2_104D_US wiring_Hennig_Chip_Conveyor

PARTS LIST IN ELECTRICAL CABINET:

- Contactor:**
 ABB B6-30-10, 120VDC coil ELE-1299
 Circuit Breaker, 15A QOU315, ELE-1338
 DIN Rail HDW-0668
Relay and Socket:
 Omron MY4N, 120 VAC, ELE-0072
 Omron PYF14A-E, ELE-1440
Receptacle:
 Hubbell HBL-4560 or equiv. ELE-0815
 (250V 2-phase, twist-lock)
 Receptacle is located where
 auger receptacle went.

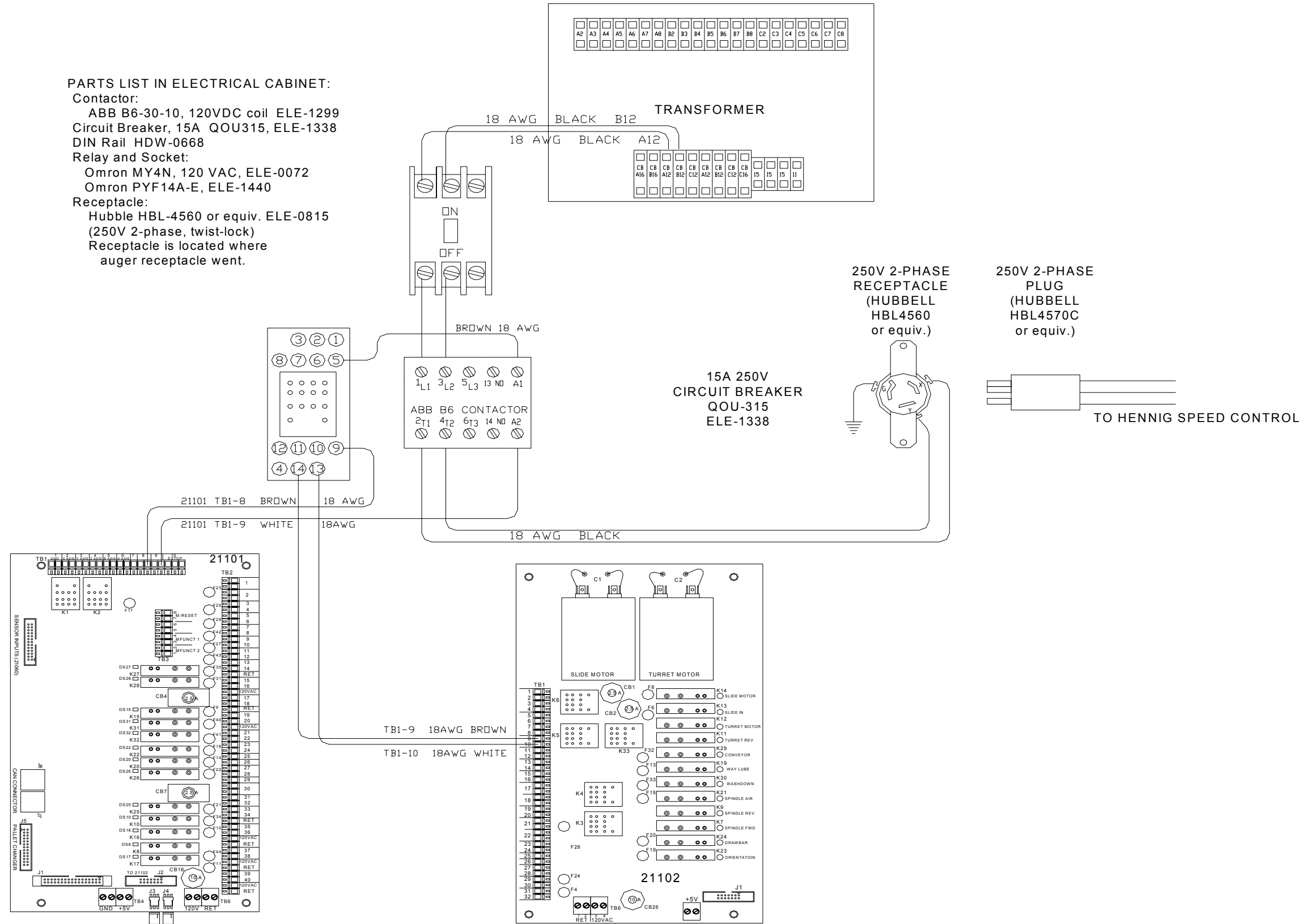

WRG_0083A_sht2of2_CE_wiring_Hennig_Chip_Conveyor 104D

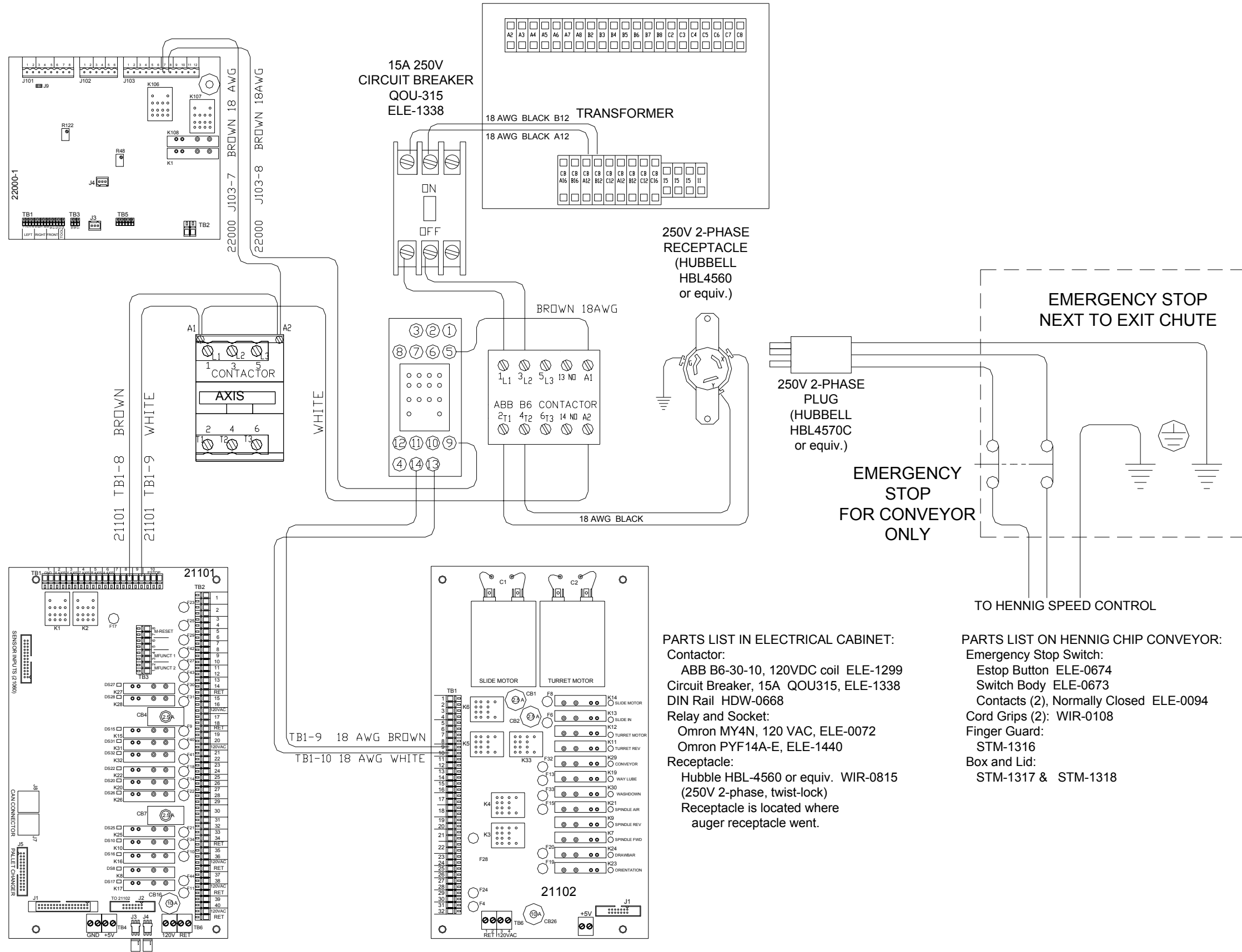

- PARTS LIST IN ELECTRICAL CABINET:**
- Contactor: ABB B6-30-10, 120VDC coil ELE-1299
 - Circuit Breaker, 15A QOU315, ELE-1338
 - DIN Rail HDW-0668
 - Relay and Socket: Omron MY4N, 120 VAC, ELE-0072
 - Omron PYF14A-E, ELE-1440
 - Receptacle: Hubbell HBL-4560 or equiv. WIR-0815 (250V 2-phase, twist-lock)
 - Receptacle is located where auger receptacle went.

- PARTS LIST ON HENNIG CHIP CONVEYOR:**
- Emergency Stop Switch: Estop Button ELE-0674
 - Switch Body ELE-0673
 - Contacts (2), Normally Closed ELE-0094
 - Cord Grips (2): WIR-0108
 - Finger Guard: STM-1316
 - Box and Lid: STM-1317 & STM-1318